

**HUAMAI**  
Make Handling Easier!

Product Catalogue



# Product Catalogue

Huamai Technology Co., Ltd

**Huamai Technology Co., Ltd**

NO.273, Lingxia West Road, Huli District, Xiamen, China, 361000

+0086-592-5194699 +0086-592-5194699

attachments@huamaiglobal.com www.huamaiattachments.com

**Huamai Technology Co., Ltd**





## ▲ ABOUT US:

- Huamai Technology Co., Ltd specializes in designing and manufacturing all kinds of forklift attachments.
- Huamai team is growing fast in the forklift attachment field with more than 20 years experience of the research, development and production. We produce different kinds of the forklift attachments such as paper roll clamps, bale clamps, block clamps, push/pulls, rotators etc.,
- The main market we sell are USA, Germany, England, Poland, Russia, Vietnam, Malaysia, Australia, Indonesia, India, South Africa for our Huamai forklift attachments.  
Come to talk with us!



## ➤ CONTENTS

● 1-Sideshifters .....	1-1
● 2-Fork Positioners .....	2-1
● 3-Rotators .....	3-1
● 4-Paper Roll Clamps .....	4-1
● 5-Bale Clamps .....	5-1
● 6-Block Clamps .....	6-1
● 7-Tobacco Carton Clamps .....	7-1
● 8-Foam Rubber Clamps .....	8-1
● 9-Multi Purpose Clamps .....	9-1
● 10-Fork Clamps .....	10-1
● 11-Turnaloads .....	11-1
● 12-Carton Clamps .....	12-1
● 13-Hinged Forks .....	13-1
● 14-Tyre Clamps .....	14-1
● 15-Drum Clamps .....	15-1
● 16-No-Arm Clamps .....	16-1
● 17-Bag Load Pushes .....	17-1
● 18-Steel Pipe Clamps .....	18-1
● 19-Hinged Brake Handlers .....	19-1
● 20-PUSH/PULLS .....	20-1
● 21-Inverta Pushes .....	21-1
● 22-Single Double Pallet Handlers .....	22-1

# Reading Instruction

## 1. Product Model

Huamai model no. Consists of letters and numbers connected by “-”, the details as below:

**RCF 20 F - 002 B**

### Name

Based on the product's functional and structural classification, an abbreviated product code is given

Example: RCF - Fixed short arm paper roll clamp

### Capacity

Capacity= Code+00 (KGS)

Example: 20-2000 KGS

### Series

The generations of the products

Example: D - The fourth generation

### Clamp arm size

It is used to distinguish the same capacity, series and types of products with different structure sizes.

Example: 002 - The maximum diameter of paper roll is 1300mm

### Mounting Class

The mounting class of the product

Example: B - III

## 2. Matching with Forklift

Please pay attention to the flow and pressure volume requirements for the attachments. Don't exceed its maximum. Any special requirements such as pressure setting etc, other auxiliary devices may need to be added. Please contact our representatives for details.

## 3. Fitting Version

Fitting size is as per GB standard, with face seal type (M18 x 1.5). For special type please contact Huamai sales.

## 4. Capacity

The load capacity is only a parameter to measure the performance of structure, and the actual comprehensive carrying capacity also depends on the carrying cargo, working conditions and the capacity of forklift. Accurate forklift truck with comprehensive load capacity, please get it from the forklift factory.

## 5. Mounting Class

The attachment is the mounting bracket of the product on the back of the product. Standard products carry these hooks and require forklift forks to meet international standards to properly mount the connection.

The meaning of installation is as follows:

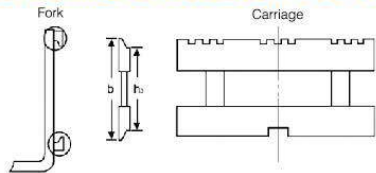

	II		III		IV		V	
Rated capacity of forklift (kg)	1000-2500		2501-4999		5000-8000		8001-10999	
Unit	mm	mm	mm	mm	mm	mm	mm	mm
b	407.00	16.02	508.00	20.00	635.00	25.00	728.00	28.66
h (maximum)	381.00	15.00	476.00	18.74	597.50	23.50	681.00	26.80
h (minimum)	380.00	14.96	474.50	19.68	595.00	23.50	678.00	26.70

## 6. Clamp Arm & Forks Length

The clamp arm & fork length listed in this product manual is the effective length for the actual operation of clamp arm & fork.

## 7. Warranty

Huamai Technology Company Ltd gives the warranty of new attachments 24 months from the date of delivery to first receiver or 4000 work hours according to the warranty policy listed in the products manuals.

## Calculation of Comprehensive Net Capacity

The capacity is an important factor in the model selection for the forklift trucks and the attachments, the overall comprehensive capacity of the forklift truck and the attachment will decline when the forklift install with the attachments because of the below two factors:

1) Part of the capacity moment may be offset by the moment of its self-weight.

2) The load center forward because of effective thickness during the actual operation.

The formula below helps to calculate the net capacity. The ultimate value of capacity for reference only.

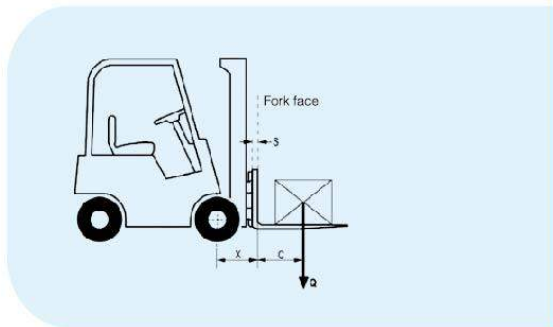

### The counting parameters of forklift

- ▶ **Q:** Rated capacity of forklift (kg) (Note: The rated capacity is relevant to the maximum height of lift)
- ▶ **X:** The horizontal distance from the center of front wheel to the fork from face (mm)
- ▶ **C:** The horizontal distance from the fork shank front face to the load center (mm)
- ▶ **S:** The thickness of fork (mm)

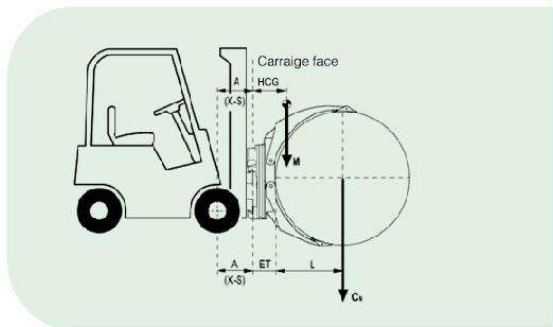

### The counting parameters of attachments

- ▶ **M:** Attachment self-weight (kg)
- ▶ **A(X-S):** The horizontal distance from center of front wheel to carriage front face (mm)
- ▶ **HCG:** The horizontal distance from front face of carriage to horizontal center of gravity (mm)
- ▶ **ET:** The horizontal distance from the carriage front face to the loaded back face (mm)
- ▶ **L:** The horizontal distance from the loaded back face to the load center (mm)

### Example:

Q= 2500kg X= 450mm C=500mm S= 50mm  
M=600kg A= 400mm HCG=300mm ET=200mm  
L=500mm

$$C_N = \frac{Q(X+C)-M(A+HCG)}{A+ET+L}$$

$$C_N = \frac{2500(450+500)-600(400+300)}{400+200+500}$$

$$C_N = 1777\text{kg}$$

### Comprehensive Net capacity (Residual capacity)

The minimum value got from the rated forklift truck load capacity, the attachment load capacity and the comprehensive net capacity as the actual capacity of the forklift trucks and the attachments as one, the weight of the carrying goods shall not exceed this allowable value.

\* The accurate comprehensive load capacity value of the forklift truck and the attachments is getting from the forklift factory.

## Warranty

**Thank you very much for purchasing Huamai attachments. In order to fully understand your rights as our customer, we recommend that you read the content of this warranty carefully.**

The following: HM refers to Huamai Technology Co., Ltd.; "Buyer" means a direct product purchaser and user.

### Huamai Products

Huamai guarantee the products comply with contracts, quotations, relevant performance parameters of the requirements listed in the manual.

### Warranty: Huamai new products.

New Products: Warranted for a period of 24 months following date of buyer receiving products, or 4000 working hours since date of installation whichever reaches the first.

### Our promise to you

Huamai will repair or replace, at our option, any parts we deem to be defective in materials or workmanship, subject either to our own or Huamai authorized inspection.

### Comprehensive net capacity

The calculation of the attachments comprehensive net capacity only for reference. The comprehensive net capacity of the forklift/attachment combination will be submitted by the original forklift manufacturer.

## Buyer and User Attention

To preserve Huamai's Warranty, Buyers and End Users must carefully follow the applicable User Manual when installing, adjusting, maintaining and operating Huamai equipment.

The buyer/end user must obtain written authorization from Huamai for repairs, other than removal/replacement of defective parts.

Any unauthorized repairs or alterations, use of parts not provided by Huamai, or failure to following Huamai User Manual will result in loss of warranty.

## Notice

Huamai does not warrant that its products will perform any particular task where conditions are not suitable for the product.

Huamai assumes no responsibility for loss, damage or injury to persons or property or for consequential damages, resulting from the possession or use of its products.

Huamai Warranty done not cover for general wear and tear, abnormal applications, normal or scheduled maintenance.

There are no warranties either expressed or implied including any warranty of fitness for a particular purpose which extend beyond those stated in this warranty and the product description on the face of Huamai order acknowledgement.

## Return/Rejection Policy

Please keep the attachments in unused condition. Please note that any actions must firstly adhere to the valid contract or additional agreement issued by Huamai.

Please submit the return permission. All costs and expenses caused are the sole responsibility of the buyer.

Where the following conditions apply, we will refuse returns.

- Be in used condition.
- Be not returned in original design.
- Special designed for customer.
- Special items mentioned in sales contract or additional agreement.

Thank you for choosing Huamai. If you have any requirements, please feel free to contact us.

### Huamai Technology Co., Ltd

Add: Unit 328&329, 3F, NO.273, Lingxia West Road, Huli District, Xiamen, China, 361000

Tel : +0086-592-5194699

Fax: +0086-592-5194699

E-mail: attachments@huamaiglobal.com

Website: www.huamaiaattachments.com

# 1 Sideshifters E-Series

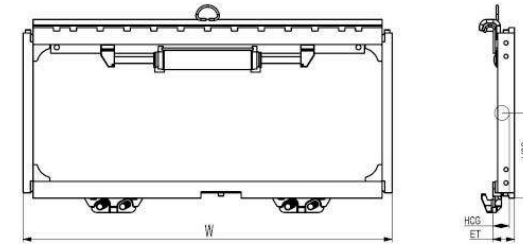

## Specification

Capacity@Load Center	Model	Mounting Class	Minimum Turck Carriage Width	Carriage Width	Vertical Center of Gravity	Weight	Effective Thickness	Horizontal Center of Gravity
(kg@mm)			(mm)	W (mm)	VCG (mm)	(Kg)	ET (mm)	HCG (mm)
2500@600	SSS25F-001B	II	895	920	226	49	62	27
2500@600	SSS25F-002B		895	970	226	50.5	62	27
2500@600	SSS25F-003B		895	1020	226	52	62	27
2500@600	SSS25F-004B		895	1040	226	53	62	27
2500@600	SSS25F-005B		1040	1070	226	54	62	27
2500@600	SSS25F-006B		1040	1100	226	55	62	27
2500@600	SSS25F-007B		1040	1200	226	58	62	27
3500@600	SSS35F-001C	III	935	1070	293	66	68	29
3500@600	SSS35F-002C		935	1100	293	67	68	29
3500@600	SSS35F-003C		1035	1115	293	68	68	29
3500@600	SSS35F-004C		1035	1150	293	69.5	68	29
3500@600	SSS35F-005C		1035	1200	293	71	68	29
3500@600	SSS35F-006C		1035	1245	293	73	68	29
3500@600	SSS35F-007C		1035	1300	293	74.5	68	29
3500@600	SSS35F-008C		1035	1350	293	77	68	29

### Note:

- ① Obtain the actual capacity of the forklift and attachments from the forklift manufacturer.
- ② One/Two sets additional oil circuit required on forklift.
- ③ Can be customized according to customer requirements of various width.
- ④ Please contact the sales from HUAMAI.

## Hydraulic Flow & Pressure

Model	Min. Hydraulic Flow(L/min)	Rec. Hydraulic Flow(L/min)	Max. Hydraulic Flow(L/min)	Rec. Hydraulic Pressure(Bar)	Max. Hydraulic Pressure(Bar)
SSS25F/SSS35F	4	8	11	155	245

## Application

Side shifter is the most common attachment installed in forklift, allowing side shifting of 100mm both leftward and rightward for the goods on the forklift fork, which is convenient to pick up and stack the goods, thus greatly improves the flexibility and moving efficiency of the forklift. It is suitable for various occasions using forklift for moving and stacking.

## Features

Integrate Cylinder and Side shifter frame into a component, saving room and widening the view.

Easy installed, directly connected to fork carriage.

Double-headed rod cylinder, keep the same thrust force and speed on both sides of cylinder.

The lower bearings used wear-resistant nylon-material to ensure smoothly move.

Highly efficiency, easy maintenance and operation.

# 1 Sideshifters D-Series

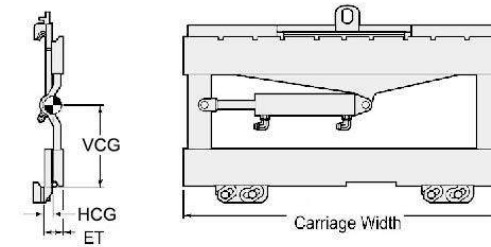

## Specification

Capacity@Load Center (kg@mm)	Model	Mounting Class	Minimum Turck Carriage Width (mm)	Carriage Width W (mm)	Vertical Center of Gravity VCG (mm)	Weight (Kg)	Effective Thickness ET (mm)	Horizontal Center of Gravity HCG (mm)
4500@600	SSS45D-001C	III	895	1000	390	140	64	33
4500@600	SSS45D-002C		965	1100	390	150	64	33
4500@600	SSS45D-003C		1016	1200	390	160	64	33
4500@600	SSS45D-004C		1170	1250	390	200	64	33
4500@600	SSS45D-005C		1210	1330	390	210	64	33
6800@600	SSS68D-001D	IV	1220	1330	440	240	84	43
6800@600	SSS68D-002D		1220	1532	440	140	77	43
6800@600	SSS68D-003D		1372	1670	440	300	84	43
6800@600	SSS68D-004D		1525	1700	440	300	84	43
6800@600	SSS68D-005D		1525	1744	440	330	84	43
6800@600	SSS68D-006D		2085	2400	440	388	84	43

### Note:

- ① Obtain the actual capacity of the forklift and attachments from the forklift manufacturer.
- ② One/Two sets additional oil circuit required on forklift
- ③ Sideshift range total :45D,200(+/-100)mm;68D,300(+/-150)mm
- ④ Can be customized according to customer requirements of various width.
- ⑤ Please contact the sales from HUAMAI.

## Hydraulic Flow & Pressure

Model	Min.Hydraulic Flow(L/min)	Rec. Hydraulic Flow(L/min)	Max.Hydraulic Flow(L/min)	Rec. Hydraulic Pressure(Bar)	Max. Hydraulic Pressure(Bar)
SSS45D	4	15	19	140	245
SSS68D	4	19	30	155	210

## Application

Side shifter is the most common attachment installed in forklift, allowing side shifting of 100mm both leftward and rightward for the goods on the forklift fork, which is convenient to pick up and stack the goods, thus greatly improves the flexibility and moving efficiency of the forklift. It is suitable for various occasions using forklift for moving and stacking.

## Features

Integrate Cylinder and Side shifter frame into a component, saving room and widening the view.

Easy installed, directly connected to fork carriage.

Double-headed rod cylinder, keep the same thrust force and speed on both sides of cylinder.

The lower bearings used wear-resistant nylon-material to ensure smoothly move.

Highly efficiency, easy maintenance and operation.



# 2 Fork Positioners D-Series



### Application

The Fork Positioner is a hydraulic attachment for forklift trucks. It is mounted on the fork carriage and enables the driver to change the opening between forks from the drivers seat. This way, loads with various widths can be picked up easily and transported safely.

- Designed for adjusting forks without leaving forklift seat.
- Used to position forks to handle different load sizes that have different fork entries/widths
- When equipped with sideshifting function, loads move side to side which eases adjustments, stacking, loading and unloading of goods

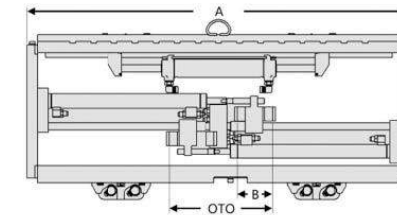
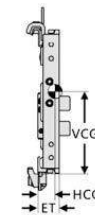

### Specification

Capacity@ Load Center	Model	Mounting Class	Opening Range	Carriage Width	Fork Pocket Width	Vertical Center of Gravity	Weight	Effective Thickness	Horizontal Center of Gravity
KG @ mm			mm	mm	mm	VCG (mm)	(kg)	ET (mm)	HCG (mm)
3500@600	FPB30D-001C	III	320-1100	1070	100-130	282	81	64	34
3500@600	FPB30D-002C	III	290-1100	1100	100-130	293	82	64	34
3500@600	FPB30D-003C	III	290-1050	1150	100-130	293	85	64	34
3500@600	FPB30D-004C	III	290-1100	1200	100-130	293	88	64	34
3500@600	FPB30D-005C	III	290-1150	1245	100-130	282	90	64	34

### Note:

- ① Obtain the actual capacity of the forklift and attachments from the forklift manufacturer.
- ② One/Two sets additional oil circuit required on forklift.
- ③ Can be customized according to customer requirements of various width.
- ④ Please contact the sales from HUAMAI.

### Hydraulic Flow & Pressure

Model	Pressure (Bar)	Hydraulic Flow (l/min.)
	Rated	Min Rec Max
FPB30D	160	30 60 80

# 2 Fork Positioners F- Series



### Application

The Fork Positioner is a hydraulic attachment for forklift trucks attachment. It is mounted on the fork carriage and enables the driver to change the opening between forks from the drivers seat. This way, loads with various widths can be picked up easily and transported safely.

- Designed for adjusting forks without leaving forklift seat
- Used to position forks to handle different load sizes that have different fork entries/widths
- When equipped with sideshifting function, loads move side to side which eases adjustments, stacking, loading and unloading of goods

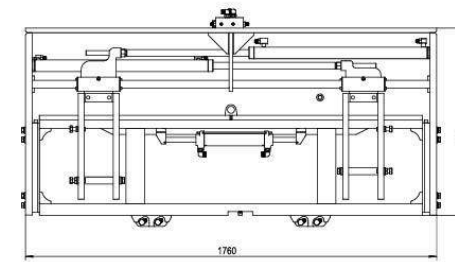

### Specification

Capacity@ Load Center	Model	Mounting Class	Overall Width	Opening Range	Truck Carriage Width	Fork Pocket Width	Overall Height	Vertical Center of Gravity	Weight	Effective Thickness	Horizontal Center of Gravity
KG @MM			(mm)	(mm)	(mm)	(mm)	(mm)	VCG (mm)	(kg)	ET (mm)	HCG (mm)
4500@600	FPB45F-001C	III	1000	400-900	895	125-150	1423	530	286	73	51
4500@600	FPB45F-002C	III	1100	400-1000	965	125-150	1423	530	296	73	51
4500@600	FPB45F-003C	III	1200	400-1100	1016	125-150	1423	530	306	73	51
4500@600	FPB45F-004C	III	1250	400-1150	1170	125-150	1423	530	311	73	51
4500@600	FPB45F-005C	III	1330	400-1230	1220	125-150	1423	530	319	73	51
6800@600	FPB68F-001D	IV	1170	400-1080	1100	135-160	1571	560	355	87	59
6800@600	FPB68F-002D	IV	1200	400-1110	1120	135-160	1571	560	358	87	59
6800@600	FPB68F-003D	IV	1550	400-1460	1220	135-160	1571	560	436	87	59
6800@600	FPB68F-004D	IV	1700	400-1610	1100	135-160	1571	560	472	87	59
6800@600	FPB68F-005D	IV	1800	400-1710	1525	135-160	1571	560	477	87	59

### Note:

- ① Obtain the actual capacity of the forklift and attachments from the forklift manufacturer.
- ② One/Two sets additional oil circuit required on forklift.
- ③ Can be customized according to customer requirements of various width.
- ④ Please contact the sales from HUAMAI.

### Hydraulic Flow & Pressure

Model	Pressure (Bar)	Hydraulic Flow (l/min.)	
		Rated	Min Rec Max
FPB 45F	160	60	100 150
FPB 68F	160	60	100 150

Fork Positioners

## 2 Fork Positioners G-Series

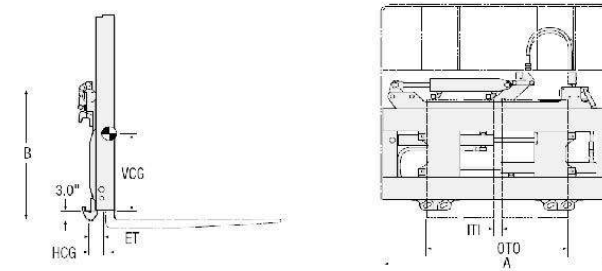
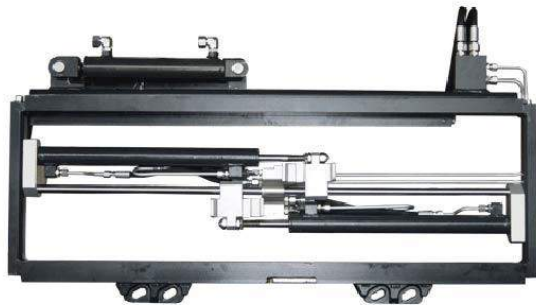

### Specification

Capacity@ Load Center	Model	Mounting Class	Opening Range	Carriage Width	Fork Pocket Width	Vertical Center of Gravity	Weight	Effective Thickness	Horizontal Center of Gravity
KG @ mm			mm	W (mm)	B (mm)	VCG (mm)	(kg)	ET (mm)	HCG (mm)
2500@600	FPB25G-001B	II	230-860	1040	80-100	226	67	62	27
3500@600	FPB35G-001C	III	250-1010	1150	80-100	226	72	62	27

#### Note:

- ① Obtain the actual capacity of the forklift and attachments from the forklift manufacturer.
- ② One/Two sets additional oil circuit required on forklift.
- ③ Can be customized according to customer requirements of various width.
- ④ Please contact the sales from HUAMAI.

### Hydraulic Flow & Pressure

Model	Pressure (Bar)	Hydraulic Flow (l/min.)
	Rated	Min Rec Max
FPB25G/FPB35G	160	30 60 80

### Application

Designed for adjusting forks without leaving drivers seat. Excellent operating vision allows operator to quickly, conveniently and accurately adjust distance of fork from the drivers seat to the ideal position for load handling, achieving continuous and efficient operation without damaging pallets of products.

- Designed for adjusting forks without leaving forklift seat
- Used to position forks to handle different load sizes that have different fork entries/widths
- When equipped with sideshifting function, loads move side to side which eases adjustments, stacking, loading and unloading of goods

## 2 Fork Positioners M-Series

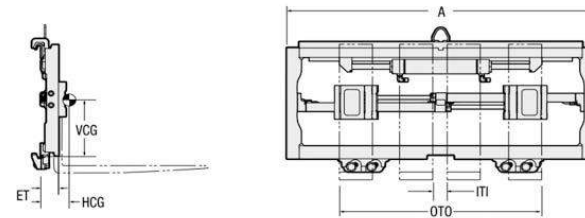
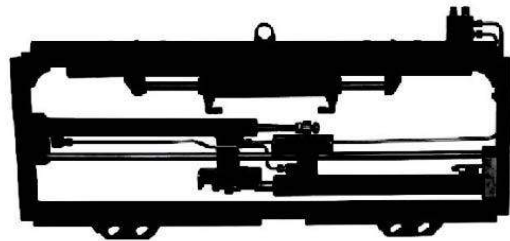

### Specification

Capacity@ Load Center	Model	Mounting Class	Opening Range	Carriage Width	Fork Pocket Width	Vertical Center of Gravity	Weight	Effective Thickness	Horizontal Center of Gravity
KG @ mm			mm	(W) mm	(B) mm	VCG (mm)	(kg)	ET (mm)	HCG (mm)
2500@600	TJC25M-001B	II	290-1050	1150	100-120	226	76	62	27
2500@600	TJC25M-002B	II	290-1000	1100	100-120	226	75	62	27
2500@600	TJC25M-003B	II	270-900	1040	90-100	226	74	62	27
2500@600	TJC25M-004B	II	290-920	1020	100-120	226	73	62	27
3500@600	TJC35M-001C	III	300-1020	1115	100-130	293	83	64	29

#### Note:

- ① Obtain the actual capacity of the forklift and attachments from the forklift manufacturer.
- ② One/Two sets additional oil circuit required on forklift.
- ③ Can be customized according to customer requirements of various width.
- ④ Please contact the sales from HUAMAI.

### Hydraulic Flow & Pressure

Model	Pressure (Bar)	Hydraulic Flow (l/min.)
	Rated	Min Rec Max
TJC25M/TJC35M	160	30 60 80

### Application

The Fork Positioner is a hydraulic attachment for forklift trucks. It is mounted on the fork carriage and enables the driver to change the opening between forks from the drivers seat. This way, loads with various widths can be picked up easily and transported safely.

- Enables operator to move forks wider apart or closer together hydraulically
- Used to position forks to handle different load sizes that has different fork entries or width
- When equipped with sideshifting function, it enables the forklift to move loads from side to side to ease stacking, loading and unloading of goods
- Used in most industries with loads of different sizes for stacking, loading

# 3 Rotators D-Series



### Application

Rotator is widely used in food, automation, chemical, materials recycling, smelting foundry industries, as well as any need to rotate the hopper or box tipping and mixing occasions, the goods can quickly flip or conversion, and then immediately coherent the fork back to its original location.

### Features

- Hydraulic system: hydraulic motor and foreign companies jointly developed by a new generation of products; rotating hinge and seal oil are imported products. Rotating two-way hydraulic oil circuit, self-locking, ensuring safety at work.
- Structural parts: the slewing bearing slewing bearings with large modulus, the load capacity; worm and worm involute tooth profile, can improve efficiency, reduce heat loss, and also to achieve self-locking feature.
- Mechanical performance: the case can be achieved with a 360° two-way rotation, a group of asphalt can be added to meet the requirements; standard fork can be used directly without modification.

### Advantages

- Proven durable construction design, unique rotating driven system, meet the high strength continuous operation.
- Strong rotating driving torque achieved the stable and reliable rotating function.
- Hydraulic motor fixed with reversible hydraulic lock, any angle position of lock function.

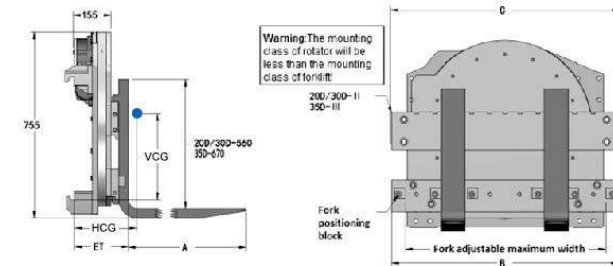

### Specification

Model	Capacity@Load Center	Truck/Rotator Mounting Class	Rotator/Forks Mounting Class	Carriage Width (mm)	Fork Max Spacing (mm)	Fork Min Spacing (mm)	Overall Width (mm)	Weight (kg)
RRB20D-001A	1700@500	II	II	815	705	610	840	188
RRB20D-002A	1600@500	II	II	815	705	610	840	254
RRB20D-003A	1600@500	II	II	815	705	610	840	259
RRB20D-004A	1600@500	II	II	815	705	610	840	268
RRB20D-005A	1600@500	II	II	815	705	610	840	277
RRB20D-006A	2200@500	II	II	815	705	813	840	300
RRB20D-007A	2200@500	II	II	940	835	813	965	309
RRB30D-008A	3000@500	II	II	940	855	813	965	313
RRB30D-008B	3000@500	III	II	940	855	813	965	329
RRB30D-009A	3000@500	II	II	1145	1060	813	1170	327
RRB30D-009B	3000@500	III	II	1145	1060	813	1170	343
RRB35D-010B	3500@500	III	III	1065	990	813	1090	390
RRB35D-011B	3500@500	III	III	1220	1140	813	1245	406
RRB50D-001B	5400@500	III	III	1065	960		1090	465
RRB50D-001C	5400@500	IV	III	1065	960		1090	518
RRB50D-002B	5400@500	III	III	1525	1418		1550	513
RRB50D-002C	5400@500	IV	III	1525	1418		1550	565
RRB50D-003C	5400@600	IV	IV	1245	1115		1285	726
RRB50D-004C	5400@600	IV	IV	1550	1420		1590	783
RRB50D-005C	5400@600	IV	IV	1855	1725		1890	840
RRB70D-001C	6800@600	IV	IV	1245	1245		1285	415
RRB70D-002C	6800@600	IV	IV	1550	1550		1590	981
RRB70D-003C	6800@600	IV	IV	1855	1855		1890	1040

### Note:

- ① Obtain the actual capacity of the forklift and attachments from the forklift manufacturer,
- ② One sets additional oil circuit required on forklift
- ③ According to user needs to increase forks. Please note the fork's capacity.
- ④ The actual mount, please according to the fork width adjustment positioning block, choose one mating surface, preventing load rotates, fork on the upper and lower cross beam under moving.
- ⑤ Please contact the sales from HUAMAI.

### Hydraulic Flow & Pressure

Model	Min. Hydraulic Flow(L/min)	Rec. Hydraulic Flow(L/min)	Max. Hydraulic Flow(L/min)	Rec. Hydraulic Pressure(Bar)	Max. Hydraulic Pressure(Bar)
RRB20D	20	40	60	35	160
RRB30D	20	40	60	35	160
RRB35D	20	40	60	35	160
RRB35D	20	40	60	35	160
RRB35G	20	40	60	35	160
RRB50D	19	38	57	35	160
RRB70D	26	45	57	35	160

### Rotator Specification

Model	Rotator Speed	Rotator Torque
RRB20D	7.0r/min@57L/min	7200N.M@160Bar
RRB30D	5.2r/min@57L/min	9000N.M@160Bar
RRB35D	5.2r/min@57L/min	9000N.M@160Bar
RRB35D	5.2r/min@57L/min	9000N.M@160Bar
RRB50D	4.1r/min@57L/min	11000N.M@160Bar
RRB70D	3.2r/min@57L/min	14000N.M@160Bar

### Options

Forks  
180 degrees rotator  
Welding type of hook

## 3 Rotators G-Series

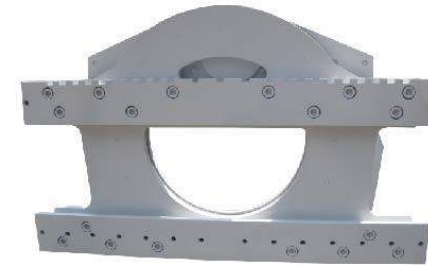

### Application

G-Series Rotator is widely used in food, automatic production, chemical, materials recycle, melting casting and other industries. The sites need rotating to tip and mix the hoppers or boxes, and it can Up or change the cargoes quickly, and then bring back the fork to the original position immediately and consistently.

### Features

- Hydraulic system: all the motors, valves and seals adopt originally imported products.
- Structural part: it adopts large-modulus slewing bearing, which has stronger bearing capacity; turbine and worm adopts Involute gears; so as not only increase the efficiency and decrease the heat loss, but also realize the self-locking function.
- Mechanical performance: it can realize the 360° two-way rotation. and it can meet the requirements Just by adding a group of oil lines; and it can directly use the standard fork without needing any modification.

### Advantages

- Proven durable construction design, unique rotating driven system, meet the high strength continuous operation.
- Strong rotating driving torque achieved the stable and reliable rotating function.
- Hydraulic motor fixed with reversible hydraulic lock, any angle position of lock function.

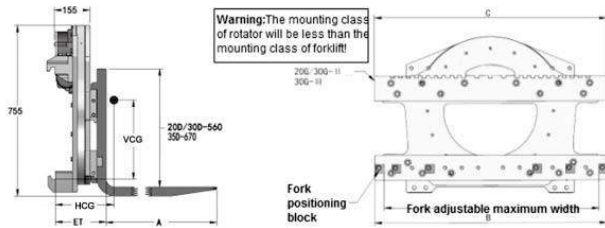

### Specification

Capacity@Load Center	Model	Truck/Rotator Mounting Class	Rotator/Fork Mounting Class	Carriage Width	Fork Max. Spacing	Overall Width	Vertical Center of Gravity	Weight	Effective Thickness	Horizontal Center of Gravity
(kg@mm)				B (mm)	OTO (mm)	C (mm)	VCG (mm)	(kg)	ET (mm)	HCG (mm)
3000@500	RRB30G-005A	II	II	940	855	965	270	313	150	81
3000@500	RRB30G-005B	III	II	940	855	965	290	329	191	114
3000@500	RRB30G-006A	II	II	1145	1060	1170	265	327	150	84
3000@500	RRB30G-006B	III	II	1145	1060	1170	285	343	191	117
3500@500	RRB35G-001B	III	III	1120	1140	1245	290	328	201	127
3500@500	RRB35G-002B	III	III	1145	1065	1145	290	406	201	127
3500@500	RRB35G-003B	III	III	1065	990	1090	290	390	201	124
3500@500	RRB35G-004B	III	III	1220	1140	1245	290	406	201	127

#### Note:

- ① Obtain the actual capacity of the forklift and attachments from the forklift manufacturer.
- ② One sets additional oil circuit required on forklift
- ③ According to user needs to increase forks. Please note the fork's capacity.
- ④ The actual mount ,please according to the fork width adjustment positioning block, choose one mating surface, preventing load rotates, fork on the upper and lower cross beam under moving.
- ⑤ Please contact the sales from HUAMAI.

### Hydraulic Flow & Pressure

Model	Min. Hydraulic Flow(L/min)	Rec. Hydraulic Flow(L/min)	Max. Hydraulic Flow(L/min)	Rec. Hydraulic Pressure(Bar)	Max. Hydraulic Pressure(Bar)
RRB30G/ RRB35G	20	40	60	35	160

### Rotator Specification

Model	Rotator Speed	Rotator Torque
RRB30G/ RRB30G	5.2r/min@57L/min	9000N.M@160Bar

### Options

- Forks
- 180 degrees rotator
- Welding type of hook

## 4 Paper Roll Clamps Heavy Duty



### Application

Heavy duty paper Roll clamps are designed to help you handling the heavy paper rolls more conveniently and efficiently. It can be widely used in mills, paper, packaging ,warehouses, printers, newspaper publishers, converters and other industries on the various types of paper rolls for efficient removal and stacking without damage operations.

### Features

- hydraulic systems: the main control valve in the load to maintain valve adopts imported products; seals are imported products; high–pressure hose with cone seal, high–performance hose.
- structural parts: the left and right plates with Q460 high–performance steel plates, and pressure by the overall shape and the correction is made; channel while using the imported product.
- mechanical performance: Built–in lateral feature, you can also achieve clamping / opening and lateral function and good vision; additional oil line can meet the requirements of the two groups.

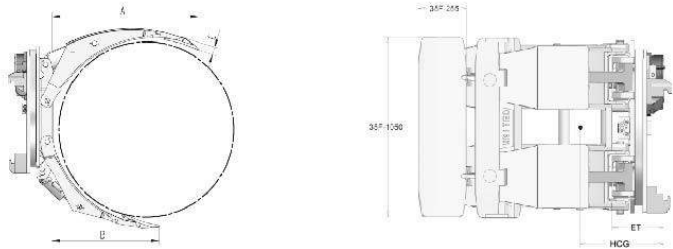

### Specification

Capacity	Roll Range	Model	Type	Mounting Class	Mounting Angle	Long Arm Thickness	Short Arm Length	Long Arm Thickness	Weight	Effective Thickness	Horizontal Center of Gravity
(kg)	(mm)					(mm)	(mm)	(mm)	(kg)	ET (mm)	HCG (mm)
2700	360-1830	RCP35F-003B	B	III	0°	1165	810	65	1289	218	353
2700	360-1830	RCP35F-003C	B	IV	0°	1165	810	65	1289	218	353
2700	635-1830	RCF35F-004B	A	III	0°	1165	810	65	1280	218	353
2700	635-1830	RCF35F-004C	A	IV	0°	1165	810	65	1289	218	353
3500	250-1520	RCP35F-001B	B	III	0°	1000	670	65	1190	218	320
3500	250-1520	RCP35F-001C	B	IV	0°	1000	670	65	1199	218	320
3500	610-1520	RCF35F-002B	A	III	0°	1000	670	65	1180	218	320
3500	610-1520	RCF35F-002C	A	IV	0°	1000	670	65	1190	218	320
4000	250-1300	RCP35F-007B	B	III	0°	875	575	65	1146	218	295
4000	250-1300	RCP35F-007C	B	IV	0°	875	575	65	1155	218	295
4000	560-1300	RCF35F-008B	A	III	0°	875	575	65	1137	218	295
4000	560-1300	RCF35F-008C	A	IV	0°	875	575	65	1146	218	295
4100	250-1520	RCP45F-001C	A	IV	2°	965	680	85	1294	198	310
4100	530-1520	RCF45F-002C	A	IV	2°	965	680	85	1285	198	310
3400	360-1830	RCP45F-003C	B	IV	2°	1105	815	85	1385	198	338
3400	660-1830	RCF45F-004C	A	IV	2°	1105	815	85	1376	198	338
4500	250-1300	RCP45F-007C	B	IV	2°	900	565	85	1242	198	284
4500	560-1300	RCF45F-008C	A	IV	2°	900	565	85	1233	198	284

#### Note:

- ① Obtain the actual capacity of the forklift and attachments from the forklift manufacturer.
- ② "A" fixed construction frame and fixed arm type, two sets additional oil circuit required on forklift.  
"B" fixed construction frame and adjustable short arm type, two sets additional oil circuit required on forklift.  
"C" Rotating construction frame and adjustable arm type, two sets additional oil circuit and magnetic valve required on forklift.
- ③ Use "0" mounting angle when stacking operation higher than 6800mm
- ④ Provide the Non-standard clamp plate as required.

### Hydraulic Flow & Pressure

Model	Min. Hydraulic Flow(L/min)	Rec. Hydraulic Flow(L/min)	Max. Hydraulic Flow(L/min)	Rec. Hydraulic Pressure(Bar)	Max. Hydraulic Pressure(Bar)
RC35F / RC45F	20	40	60	35	160

### Rotator Specification

Model	Rotator Speed	Rotator Torque
RC35F / RC45F	5.2r/min@57L/min	9000N.M@160Bar

### Options

- Custom opening ranges
- Positioned short arm or fixed short arm
- Split long arm
- Special pads, Rubber pad, Polyurethane pad



# 4 Paper Roll Clamps Single Arm



### Application

Single arm paper roll clamps are suitable for small tonnage paper roll or circular goods clamping, structure design for single arm, reduce cost, weight, and improve efficiency.

### Features

- Fixed short arm for single large diameter paper rolls
- Positioned short arm for various diameters
- Short arm adjustable for handling small size rolls
- Split arms for handling two different size paper rolls simultaneously

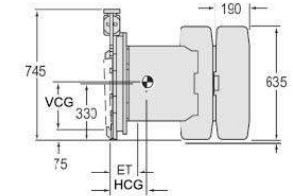
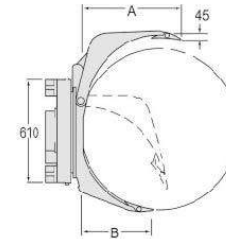

### Specification

Capacity (kg)	Roll Range (mm)	Model	Type	Mounting Class	Mounting Angle	Long Arm Length A(mm)	Short Arm Length B(mm)	Vertical Center of Gravity VCG (mm)	Weight (kg)	Effective Thickness ET (mm)	Horizontal Center of Gravity HCG (mm)
1200	410-1300	RCF15F-013A	A	II	0°	790	580	330	354	135	221
1300	330-1150	RCF15F-014A	A	II	0°	685	515	330	343	135	216
1100	450-1500	RCF15F-015A	A	II	1.5°	890	680	330	435	150	270
1000	560-1600	RCF15F-016A	A	II	1.5°	940	730	330	455	150	290

### Note:

- ① Obtain the actual capacity of the forklift and attachments from the forklift manufacturer.
- ② "A" fixed construction frame and fixed arm type, two sets additional oil circuit required on forklift.  
"B" fixed construction frame and adjustable short arm type, two sets additional oil circuit required on forklift.  
"C" Rotating construction frame and adjustable arm type, two sets additional oil circuit and magnetic valve required on forklift.
- ③ Use "0°" mounting angle when stacking operation higher than 6800mm
- ④ Provide the Non-standard clamp plate as required.
- ⑤ Please contact the sales from HUAMAI.

### Hydraulic Flow & Pressure

Model	Min. Hydraulic Flow(L/min)	Rec. Hydraulic Flow(L/min)	Max. Hydraulic Flow(L/min)	Rec. Hydraulic Pressure(Bar)	Max. Hydraulic Pressure(Bar)
RC15F	20	40	60	35	160

### Rotator Specification

Model	Rotator Speed	Rotator Torque
RC15F	5.2r/min@57L/min	9000N.M@160Bar

### Options

- Special pads, Rubber pad, Polyurethane pad
- Bar splint
- Single arc bottom paper pad

# 4 Paper Roll Clamps Standard



### Application

Paper Roll clamps are suitable for all kinds of paper, packaging, printing and other industries on the various types of paper rolls for efficient removal and stacking without damage operations.

### Features

- Hydraulic systems: the main control valve in the load to maintain valve adopts imported products; seals are imported products; high-pressure hose with cone seal, high-performance hose.
- Structural parts: the left and right plates with Q460 high-performance steel plates, and pressure by the overall shape and the correction is made; channel while using the imported product.
- Mechanical performance: Built-in lateral feature, you can also achieve clamping / opening and lateral function and good vision; additional oil line can meet the requirements of the two groups.

### Advantages

- Rational designed, compact structure, excellent driver visibility, easy operating, improve work efficiency.
- Thin arm prolife and smooth arm contour eases roll break out and permits close stacking.
- Contact pads with integral casting structure, abrasion resistance, long service life. Contact pads surface reasonable, provide the best clamping friction.
- Hydraulic retention of cylinder valves is to ensure reliable clamping of long distance transportation.
- Continuous 360° rotation, any angle position of lock function, revolving positing 90° or 180°.

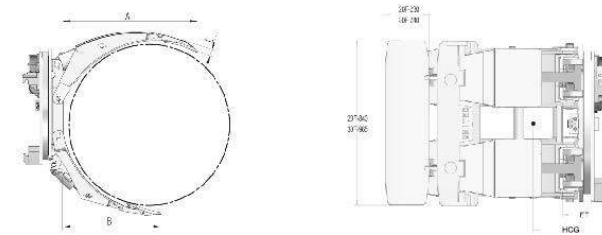

### Specification

Capacity (kg)	Roll Range (mm)	Model	Type	Mounting Class	Long Arm Length A (mm)	Short Arm Length B (mm)	Long Arm Length C (mm)	Weight (kg)	Effective Thickness ET (mm)	Horizontal Center of Gravity HCG (mm)
2000	250-1300	RCP20F-001A	B	II	825	570	45	677	197	287
2000	250-1300	RCP20F-001B	B	III	825	570	45	690	237	325
2000	630-1300	RCF20F-002A	A	II	825	570	45	667	197	282
2000	630-1300	RCF20F-002B	A	III	825	570	45	681	237	320
2000	250-1500	RCP20F-003A	B	II	955	775	95	751	197	283
2000	250-1500	RCP20F-003B	B	III	955	775	95	765	237	307
2000	530-1500	RCF20F-004A	A	II	955	775	95	744	197	280
2000	530-1500	RCF20F-004B	A	III	955	775	95	758	237	304
2000	630-1600	RCF20F-005A/B	A	II/III	955	775	95	755	183/216	301
2000	350-1600	RCP20F-006A/B	B	II/III	955	775	95	765	183/216	304
1700	680-1830	RCF20F-007B	A	III	1130	930	115	880	239	445
1700	380-1830	RCP20F-008B	B	III	1130	930	115	886	239	445
2700	330-1350	RCP30F-009B	B	III	850	570	65	759	198	272
2700	590-1350	RCF30F-012B	A	III	850	570	65	752	198	272
2700	250-1520	RCP30F-011B	B	III	955	685	50	830	198	307
2700	560-1520	RCF30F-010B	A	III	955	685	50	823	198	307
2000	250-1300	RCS20D-001A	C	II	825	560	45	717	197	269
2000	250-1300	RCS20D-001B	C	III	825	560	45	731	237	307
2700	250-1300	RCS30D-002A	C	II	845	570	70	854	203	307
2700	250-1300	RCS30D-002B	C	III	845	570	70	858	198	307

### Note:

- ① Obtain the actual capacity of the forklift and attachments from the forklift manufacturer.
- ② "A" fixed construction frame and fixed arm type, two sets additional oil circuit required on forklift.
- "B" fixed construction frame and adjustable short arm type, two sets additional oil circuit required on forklift.
- "C" Rotating construction frame and adjustable arm type, two sets additional oil circuit and magnetic valve required on forklift.
- ③ Use "0" mounting angle when stacking operation higher than 6800mm
- ④ Provide the Non-standard clamp plate as required.
- ⑤ Please contact the sales from HUAMAI.

### Hydraulic Flow & Pressure

Model	Min. Hydraulic Flow(L/min)	Rec. Hydraulic Flow(L/min)	Max. Hydraulic Flow(L/min)	Rec. Hydraulic Pressure(Bar)	Max. Hydraulic Pressure(Bar)
RC20F	20	40	60	35	160
RC20D	20	40	60	35	160
RC30F	20	40	60	35	160
RC30D	20	40	60	35	160

### Rotator Specification

Model	Rotator Speed	Rotator Torque
RC20F	5.2r/min@57L/min	9000N.M@160Bar
RC20D	5.2r/min@57L/min	9000N.M@160Bar
RC30F	5.2r/min@57L/min	11000N.M@160Bar
RC30D	5.2r/min@57L/min	11000N.M@160Bar

### Options

- Custom opening ranges
- Positioned short arm or fixed short arm
- Split long arm
- Special pads, Rubber pad, Polyurethane pad

# 4 Paper Roll Clamps G-Series



### Application

Paper roll clamps are suitable for small tonnage paper roll or circular goods clamping, structure design for single arm, reduce cost, weight, and improve efficiency.

### Features

- Fixed short arm for single large diameter paper rolls
- Positioned short arm for various diameters
- Short arm adjustable for handling small size rolls
- Split arms for handling two different size paper rolls simultaneously

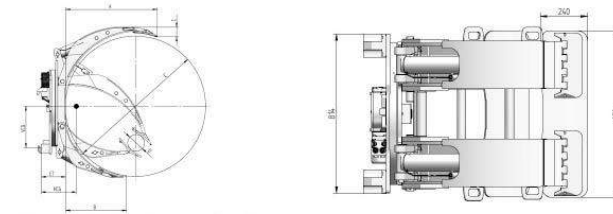

### Specification

Capacity ( kg )	Roll Range D-E ( mm )	Model	Type	Mounting Class	Mounting Angle	Long Arm Thicknes s	Short Arm Length	Long Arm Thicknes s	Vertical Center of Gravity	Weight ( kg )	Effective Thickness ET ( mm )	Horizonta l Center of Gravity CGH ( mm )
						A ( mm )	B ( mm )	C ( mm )	VCG ( mm )			
<b>22G Series</b>												
2200	350-1150	RCF22G-001B	A	III	0°	813	515	36	361	609	237	270
2200	440-1300	RCF22G-003B	A	III	0°	896	583	36	361	635	237	296
2200	440-1400	RCF22G-005B	A	III	0°	953	623	36	361	650	237	299
2000	490-1525	RCF22G-007B	A	III	0°	1013	685	36	361	665	237	328
2000	500-1600	RCF22G-009B	A	III	0°	1047	723	36	361	680	237	332
2200	200-1150	RCP22G-002B	B	III	0°	813	515	36	361	614	237	270
2200	200-1300	RCP22G-004B	B	III	0°	896	583	36	361	640	237	296
2200	200-1400	RCP22G-006B	B	III	0°	953	623	36	361	655	237	299
2000	200-1525	RCP22G-008B	B	III	0°	1013	685	36	361	672	237	328
2000	200-1600	RCP22G-010B	B	III	0°	1047	723	36	361	690	237	332
<b>30G Series</b>												
2800	575-1400	RCF30G-005B	A	III	0°	953	624	43	429	745	195	268
2550	575-1525	RCF30G-007B	A	III	0°	1005	695	43	429	765	195	286
2500	625-1600	RCF30G-009B	A	III	0°	1098	739	43	429	785	195	287
2800	200-1400	RCF30G-006B	A	III	0°	953	624	43	429	763	195	268
2550	200-1525	RCP30G-008B	B	III	0°	1005	695	43	429	781	195	286
2500	200-1600	RCP30G-010B	B	III	0°	1098	739	43	429	798	195	287

### Note:

- ① Obtain the actual capacity of the forklift and attachments from the forklift manufacturer.
- ② "A" fixed construction frame and fixed arm type, two sets additional oil circuit required on forklift.
- ③ "B" fixed construction frame and adjustable short arm type, two sets additional oil circuit required on forklift.
- ④ "C" Rotating construction frame and adjustable arm type, two sets additional oil circuit and magnetic valve required on forklift.
- ⑤ Use "0°" mounting angle when stacking operation higher than 6800mm
- ⑥ Provide the Non-standard clamp plate as required.
- ⑦ Please contact the sales from HUAMAI.

### Hydraulic Flow & Pressure

Model	Min. Hydraulic Flow(L/min)	Rec. Hydraulic Flow(L/min)	Max. Hydraulic Flow(L/min)	Rec. Hydraulic Pressure(Bar)	Max. Hydraulic Pressure(Bar)
RC22G / RC30G	20	40	60	35	160

### Rotator Specification

Model	Rotator Speed	Rotator Torque
RC22G / RC30G	5.2r/min@57L/min	9000N.M@160Bar

### Options

Custom opening ranges  
Positioned short arm or fixed short arm  
Split long arm  
Special pads, Rubber pad, Polyurethane pad

# 5 Bale Clamps A-Series



### Application

Economic Bale Clamps can efficiently and economically handle nearly any type of baled products including cotton, wool, synthetic, textile bales, corrugated, newsprint, rag, hay, metal, and other scrap bales. High efficiency and economy to handle in without platform condition.

### Features

- Proven durable T-beam arm aluminum frame construction.
- Superior arm-side bearing for extended service life.
- Ribs provide secure grip and give driver good tip handling and bale spinning capabilities.
- Regenerative hydraulic valve for optimal arm speed.
- High-strength all-steel structure design, allows high efficiency under continuous operation, good effect.
- E-slot in the overall framework to improve the stability of product, to extend the longevity of product.
- Reasonable design, nice outlook, using the world's most high-quality hydraulic components.

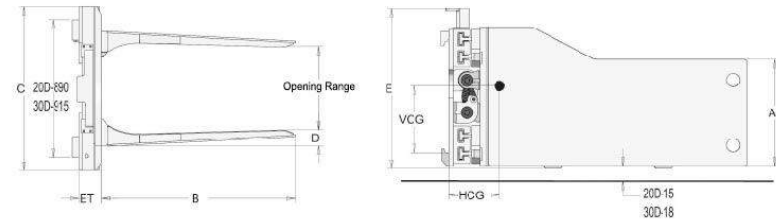

### Specification

Capacity/ Load Center (kg@mm)	Model	Mounting Class	Opening Range (mm)	Arm Height A (mm)	Arm Length B (mm)	Frame Width C (mm)	Arm Thickness D	Overall Height H (mm)	Vertical Center of Gravity VCG (mm)	Weight (kg)	Effective Thickness ET (mm)	Horizontal Center of Gravity HCG (mm)
1700@500	BCS20A-001A	II	455-1735	420	685	1040	82	665	220	310	127	203
1700@500	BCS20A-002A	II	455-1735	420	785	1040	82	665	220	337	127	239
1700@500	BCS20A-003A	II	450-1735	420	915	1040	82	665	220	378	127	307
1700@500	BCS20A-004A	II	450-1735	420	991	1040	82	665	220	382	127	315
1700@500	BCS20A-005A	II	450-1735	420	1194	1040	82	665	220	425	127	401
2500@500	BCS30A-006A	II	550-1900	480	991	1015	98	730	255	516	142	315
2500@500	BCS30A-001B	III	550-1900	480	991	1015	98	730	255	519	150	312
2500@500	BCS30A-002B	II	545-1890	480	1194	1015	98	730	255	574	142	396
2500@500	BCS30A-003B	III	545-1890	480	1194	1015	98	730	255	590	150	391
2500@500	BCS30A-004B	II	550-1900	480	915	1015	98	730	255	498	142	307
2500@500	BCS30A-005B	III	550-1900	480	915	1015	98	730	255	501	150	305
2200@500	BCS30A-006B	III	490-2300	480	990	1600	98	730	255	660	150	240
2200@500	BCS30A-007B	III	490-2300	480	1195	1600	98	730	255	680	150	240

### Note:

- ① Obtain the actual capacity of the forklift and attachments from the forklift manufacturer.
- ② Two sets additional oil circuit required on forklift
- ③ Open arm range is the space between two arms tip.
- ④ Arm thickness " D " is the actual requested operation space.
- ⑤ Please contact the sales from HUAMAI.

### Hydraulic Flow & Pressure

Model	Min. Hydraulic Flow(L/min)	Rec. Hydraulic Flow(L/min)	Max. Hydraulic Flow(L/min)	Rec. Hydraulic Pressure(Bar)	Max. Hydraulic Pressure(Bar)
BCS20A	15	25	25	35	160
BCS30A	15	40	40	35	160

### Options

- Zigzag bar splint
- Left and right clip arm independent movement type
- 180 degree rotation stopping mechanism

# 5 Bale Clamps D-Series

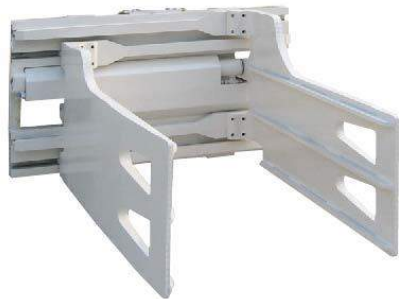

### Application

Bale Clamps can efficiently and economically handle nearly any type of baled products including cotton, wool, synthetic, textile bales, corrugated, newsprint, rag, hay, metal, and other scrap bales. High efficiency and economy to handle in without platform condition.

### Features

- Proven durable T-beam arm aluminum frame construction.
- Superior arm-side bearing for extended service life.
- Ribs provide secure grip and give driver good tip handling and bale spinning capabilities.
- Regenerative hydraulic value for optimal arm speed.
- High-strength all-steel structure design, allows high efficiency under continuous operation, good effect.
- E-slot in the overall framework to improve the stability of product, to extend the longevity of product.
- Reasonable design, nice outlook, using the world's most high-quality hydraulic components.

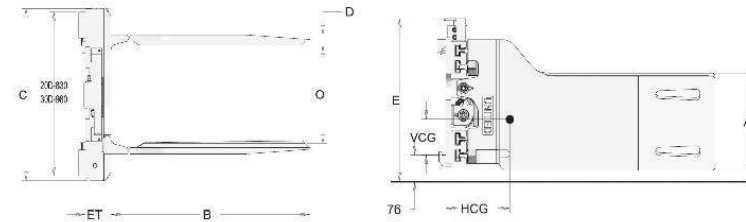

### Specification

Capacity/ Load Center	Model	Mounting Class	Opening Range	Arm Height	Arm Length	Frame Width	Overall Height	Vertical Center of Gravity	Weight	Effective Thickness	Horizontal Center of Gravity
(kg@mm)			(mm)	A (mm)	B (mm)	C (mm)	H (mm)	VCG (mm)	(kg)	ET (mm)	HCG (mm)
1400@500	BCS15D-001A	II	420-1570	415	990	940	645	220	415	127	315
1400@500	BCS15D-002A	II	420-1570	415	915	940	645	220	405	127	307
1900@500	BCS20D-003A	II	455-1735	415	685	1040	665	220	350	127	203
1900@500	BCS20D-004A	II	455-1735	415	785	1040	665	220	377	127	239
1900@500	BCS20D-005A	II	450-1730	415	915	1040	665	220	418	127	307
1900@500	BCS20D-006A	II	450-1730	415	991	1040	665	220	422	127	315
1900@500	BCS20D-007A	II	450-1730	415	1194	1040	665	220	465	127	401
2700@500	BCS30D-008A	II	550-1900	460	991	1015	730	255	556	142	315
2700@500	BCS30D-008B	III	550-1900	460	991	1015	730	255	579	150	312
2700@500	BCS30D-009A	II	545-1890	460	1194	1015	730	255	624	142	396
2700@500	BCS30D-009B	III	545-1890	460	1194	1015	730	255	640	150	391
2700@500	BCS30D-010A	II	550-1900	460	915	1015	730	255	538	142	307
2700@500	BCS30D-010B	III	550-1900	460	915	1015	730	255	538	150	305
2200@500	BCS30D-011B	III	490-2300	460	990	1600	730	255	710	150	240
2200@500	BCS30D-012B	III	490-2300	460	1195	1600	730	255	730	150	240

### Note:

- ① Obtain the actual capacity of the forklift and attachments from the forklift manufacturer.
- ② Two sets additional oil circuit required on forklift
- ③ Open arm range is the space between two arms tip.
- ④ Arm thickness " D " is the actual requested operation space.
- ⑤ Please contact the sales from HUAMAI.

### Hydraulic Flow & Pressure

Model	Min. Hydraulic Flow(L/min)	Rec. Hydraulic Flow(L/min)	Max. Hydraulic Flow(L/min)	Min. Hydraulic Pressure(Bar)	Max. Hydraulic Pressure(Bar)
BCS15D	15	25	25	35	160
BCS20D	15	25	25	35	160
BCS30D	15	40	40	35	160

### Options

- Zigzag bar splint
- Left and right clip arm independent movement type
- 180 degree rotation stopping mechanism

# 5 Bale Clamps F-Series



### Application

Bale Clamps can efficiently and economically handle nearly any type of baled products including cotton, wool, synthetic, textile bales, corrugated, newsprint, rag, hay, metal, and other scrap bales. High efficiency and economy to handle in without platform condition.

### Features

- Proven durable T-beam arm aluminum frame construction.
- Superior arm-side bearing for extended service life.
- Ribs provide secure grip and give driver good tip handling and bale spinning capabilities.
- Regenerative hydraulic valve for optimal arm speed.
- High-strength all-steel structure design, allows high efficiency under continuous operation, good effect.
- E-slot in the overall framework to improve the stability of product, to extend the longevity of product.
- Reasonable design, nice outlook, using the world's most high-quality hydraulic components.

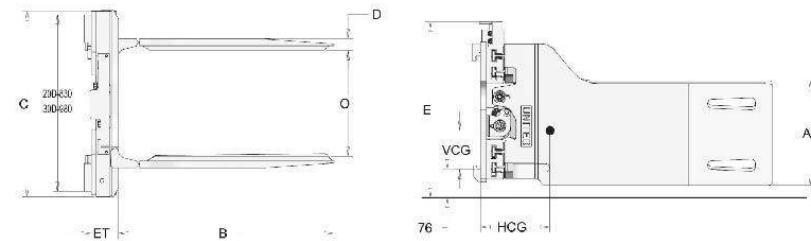

### Specification

Capacity/ Load Center (kg@mm)	Model	Mounting Class	Opening Range (mm)	Arm Height A (mm)	Arm Length B (mm)	Frame Width C (mm)	Arm Thickness D (mm)	Overall Height H (mm)	Vertical Center of Gravity VCG (mm)	Weight (kg)	Effective Thickness ET (mm)	Horizontal Center of Gravity HCG (mm)
3000@500	BCS30F-001A	II	520-1870	460	1200	1130	75	740	250	620	150	345
3000@500	BCS30F-001B	III	520-1870	460	1200	1130	75	740	250	620	150	345
3000@500	BCS30F-002A	II	750-2100	460	1200	1265	75	740	250	650	150	350
3000@500	BCS30F-002B	III	750-2100	460	1200	1265	75	740	250	650	150	350
2500@500	BCS30F-003A	II	460-2300	460	1200	1680	75	740	250	750	150	300
2500@500	BCS30F-003B	III	460-2300	460	1200	1680	75	740	250	750	150	345
3000@500	BCS30F-004A	II	585-2000	460	1200	1265	75	740	250	625	150	345
3000@500	BCS30F-004B	III	585-2000	460	1200	1265	75	740	250	625	150	300
2500@500	BCS30F-005A	II	460-2330	460	1000	1680	75	740	250	730	150	300
2500@500	BCS30F-005B	III	460-2330	460	1000	1680	75	740	250	730	150	300
2800@500	BCS30F-006A	II	815-2230	460	1200	1330	75	740	250	730	150	345
2800@500	BCS30F-006B	III	815-2230	460	1200	1330	75	740	250	730	150	345

### Note:

- ① Obtain the actual capacity of the forklift and attachments from the forklift manufacturer.
- ② Two sets additional oil circuit required on forklift
- ③ Open arm range is the space between two arms tip.
- ④ Arm thickness "D" is the actual requested operation space.
- ⑤ Please contact the sales from HUAMAI.

### Hydraulic Flow & Pressure

Model	Min. Hydraulic Flow(L/min)	Rec. Hydraulic Flow(L/min)	Max. Hydraulic Flow(L/min)	Rec. Hydraulic Pressure(Bar)	Max. Hydraulic Pressure(Bar)
BCS30F	15	40	40	35	160

### Options

Zigzag bar splint

Left and right clip arm independent movement type

180 degree rotation stopping mechanism

# 5 Bale Clamps Heavy Duty



## Application

Heavy duty bale clamps are designed to handle heavy bale products whose weight are from 4.0 Tons to 6.5 Tons. Heavy duty bale clamp can help you operate almost every bales efficiently and economically, the bales are including textile bales, corrugated, rag, newsprint, hay, metal and other scrap bales. Huamai heavy duty bale clamp greatly appreciated in the markets based on the high quality and reliable performance. You are welcome to contact us if you need higher capacity bale clamps or total solutions of your business.

## Features

- Proven durable T-beam arm aluminum frame construction.
- Superior arm-side bearing for extended service life.
- Ribs provide secure grip and give driver good tip handling and bale spinning capabilities.
- Regenerative hydraulic valve for optimal arm speed.
- High-strength all-steel structure design, allows high efficiency under continuous operation, good effect.
- E-slot in the overall framework to improve the stability of product, to extend the longevity of product.
- Reasonable design, nice outlook, using the world's most high-quality hydraulic components.

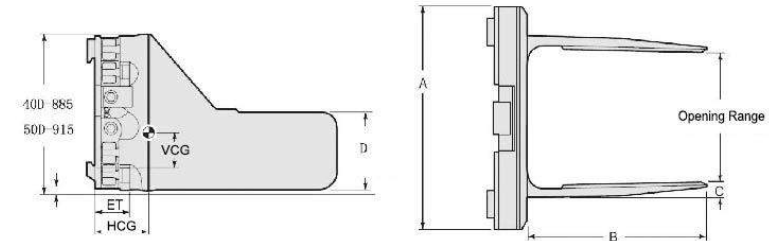

## Specification

Capacity@ Load Center (kg@mm)	Model	Mounting Class	Opening Range (mm)	Frame Width (mm)	Arm Length (mm)	Arm Thickness (mm)	Weight (kg)	Effective Thickness ET (mm)	Horizontal Center of Gravity HCG (mm)
4000@600	PBS40D-001C	IV	490-2115	1370	1200	85	1000	178	390
4000@600	PBS40D-002C	IV	480-2105	1370	1400	90	1060	178	395
4000@600	PBS40D-003C	IV	555-2560	1690	1200	85	1120	178	405
4000@600	PBS40D-004C	IV	545-2550	1690	1400	90	1180	178	410
5000@800	PBS50D-001C	IV	650-2370	1475	1200	106	1205	190	242
5000@800	PBS50D-002C	IV	550-2270	1575	1200	106	1230	190	237
5000@800	PBS50D-003C	IV	700-3100	1980	1200	106	1335	190	217
5000@800	PBS50D-004C	IV	600-3000	2080	1200	106	1360	190	207
5000@800	PBS50D-005C	IV	500-2900	2180	1200	106	1385	190	202
5000@800	PBS50D-006C	IV	620-2340	1475	1400	110	1245	190	280
5000@800	PBS50D-007C	IV	520-2240	1575	1400	110	1270	190	275
5000@800	PBS50D-008C	IV	670-3070	1980	1400	110	1375	190	255
5000@800	PBS50D-009C	IV	570-2970	2080	1400	110	1400	190	245
5000@800	PBS50D-010C	IV	470-2870	2180	1400	110	1425	190	240
5000@800	PBS50D-011C	IV	650-2370	1475	1600	115	1295	190	317
5000@800	PBS50D-012C	IV	520-2240	1575	1600	115	1320	190	312
6500@800	PBS65D-013C	IV	700-3100	2100	1600	140	1760	225	380

### Note:

- ① Obtain the actual capacity of the forklift and attachments from the forklift manufacturer.
- ② Two sets additional oil circuit required on forklift
- ③ Open arm range is the space between two arms tip.
- ④ Arm thickness" D" is the actual requested operation space.
- ⑤ Please contact the sales from HUAMAI.

## Hydraulic Flow & Pressure

Model	Min. Hydraulic Flow(L/min)	Rec. Hydraulic Flow(L/min)	Max. Hydraulic Flow(L/min)	Rec. Hydraulic Pressure(Bar)	Max. Hydraulic Pressure(Bar)
PBS40D	38	53	64	35	160
PBS50D	38	57	91	35	160
PBS65D	38	57	91	35	160

## Options

- Zigzag bar splint
- Left and right clip arm independent movement type
- 180 degree rotation stopping mechanism

# 6 Block Clamps Sideshifting



### Application

Flat holding block clamps can efficiently and safely handle various types of solid, regular cubic goods under normal temperature. Forklift block clamps are widely used in construction material, metallurgy industries for handling concrete blocks, cement bricks, carbon cubes, etc. The high structural strength and durability ensure the safe, productive application and long service life.

### Features

- Proven durable T-beam arm aluminum frame construction.
- Superior arm-side bearing for extended service life.
- Regenerative hydraulic valving for optimal arm speed.
- Durable contact pads, reliable clamping.
- Excellent driver visibility.

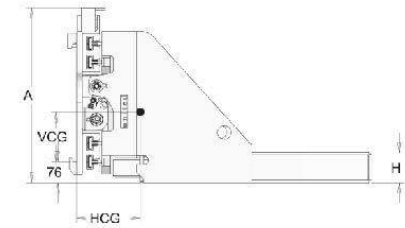
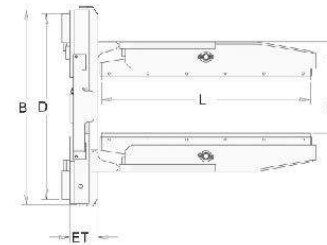

### Specification

Capacity @ Load Center	Model	Mounting Class	Opening Range	Arm Height	Arm Length	Frame Width	Arm Thickness	Overall Height	Vertical Center of Gravity	Weight	Effective Thickness	Horizontal Center of Gravity
(kg @ mm)			(mm)	(mm)	(mm)	(mm)	T (mm)	(mm)	VCG (mm)	(kg)	ET (mm)	HCG (mm)
2700/500	CKS30D-001A	II	290-1610	128	1100	1016	202	710	220	500	145	220
2700/500	CKS30D-002A	II	290-1610	242	1100	1016	202	710	220	550	145	220
2700/500	CKS30D-003A	II	290-1610	128	1000	1016	202	710	220	490	145	211
2700/500	CKS30D-001B	III	290-1610	128	1100	1016	202	710	220	500	152	220
2700/500	CKS30D-002B	III	290-1610	242	1100	1016	202	710	220	550	152	220
2700/500	CKS30D-003B	III	290-1610	128	1000	1016	202	710	220	490	152	220
2700/500	CKS30D-004B	III	290-1610	242	1400	1016	202	710	220	650	152	250

### Note:

- ① Obtain the actual capacity of the forklift and attachments from the forklift manufacturer.
- ② Two sets additional oil circuit required on forklift.
- ③ Arm height 128mm is single rubber type, arm height 242mm is double rubber type.
- ④ Please contact the sales from HUAMAI.

### Hydraulic Flow & Pressure

Model	Min. Hydraulic Flow(L/min)	Rec. Hydraulic Flow(L/min)	Max. Hydraulic Flow(L/min)	Min. Hydraulic Pressure(Bar)	Max. Hydraulic Pressure(Bar)
CKS30D	15	40	40	35	160

### Options

- Custom opening ranges
- Various material facing arm
- Various mounting classes available
- Load backrests



# 6 Block Clamps Slip On Forks



### Application

Slip-on Arm Block Clamps can efficiently and safely handle various types of solid, regular cubic goods under normal temperature.

Slip-on Arm Block Clamps are widely used in construction material, metallurgy industries for handling concrete blocks, cement bricks, carbon cubes, etc. The high structural strength and durability ensure the safe, productive application and long service life.

### Features:

- Easy to use, Can use as fork clamps, more flexible, also can save money.
- Proven durable T-beam arm aluminum frame construction.
- Superior arm-side bearing for extended service life.
- Regenerative hydraulic valving for optimal arm speed.
- Durable contact pads, reliable clamping.
- Excellent driver visibility.

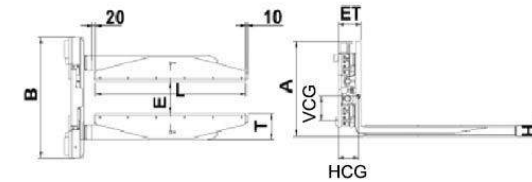

### Specification

Capacity @ Load Center (kg @ mm)	Model	Mounting Class	Opening Range (mm)	Arm Height (mm)	Arm Length (mm)	Frame Width (mm)	Arm Thickness T (mm)	Overall Height (mm)	Vertical Center of Gravity VCG (mm)	Weight (kg)	Effective Thickness ET (mm)	Horizontal Center of Gravity HCG (mm)
2500/550	CKS30D-101A	II	270-1610	94	1100	1016	202	710	210	430	208	200
2500/550	CKS30D-101B	III	270-1610	94	1100	1016	202	710	210	450	216	210
1980/700	CKS30D-102B	III	270-1610	94	1400	1016	202	710	192	480	216	220
2600/510	CKS30D-103A	II	270-1610	94	1020	1016	202	710	210	425	208	200
2600/510	CKS30D-103B	III	270-1610	94	1020	1016	202	710	210	445	216	210
1950/650	CKS30D-104B	III	270-1610	94	1300	1016	202	710	192	500	266	220

### Note:

- ① Obtain the actual capacity of the forklift and attachments from the forklift manufacturer.
- ② Please contact the sales from HUAMAI.

### Hydraulic Flow & Pressure

Model	Min. Hydraulic Flow(L/min)	Rec. Hydraulic Flow(L/min)	Max. Hydraulic Flow(L/min)	Min. Hydraulic Pressure(Bar)	Max. Hydraulic Pressure(Bar)
CKS30D	15	40	40	35	160

### Options

- Left and right clip arm independent movement type
- Custom opening ranges
- Various material facing arm
- Various mounting classes available
- Load backrests

# 7 Tobacco Carton Clamps



## Application

Tobacco carton clamps can efficiently and economically handle paper carton, wooden carton, metal carton and other scrap bales. Applicable in such fields as storage, home electric appliance and electronics for handling and stacking paper carton goods without a tray.

## Features

- Specific contact pad for various applications.
- Small-strip type rubber board works to increase abrasion coefficient to clamp goods safely.
- Excellent operation field for vision.
- Visible manometer is attached for the control of oil pressure coefficient.
- Intelligent valve is attached for the regulation of oil pressure flow.

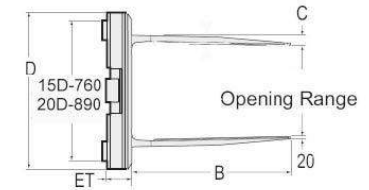
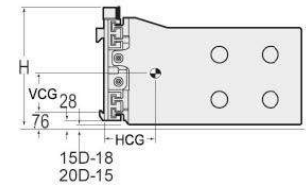

## Specification

Capacity/ Load Center (kg@mm)	Model	Mounting Class	Opening Range (mm)	Arm Height A (mm)	Arm Length B (mm)	Frame Width D (mm)	Arm Thickness C (mm)	Overall Height H (mm)	Vertical Center of Gravity VCG (mm)	Weight (kg)	Effective Thickness ET (mm)	Horizontal Center of Gravity HCG (mm)
1400@500	MTS15D-001A	II	460-1600	580	930	940	35	665	220	420	127	300
1400@500	MTS15D-002A	II	460-1600	580	1130	940	35	665	220	450	127	380
1400@500	MTS15D-003A	II	460-1600	580	1130	940	35	665	263	430	127	380
1900@500	MTS20D-004A	II	480-1760	580	1130	1040	37	665	260	480	127	380
1900@500	MTS20D-005A	II	480-1760	580	1330	1040	37	665	260	500	127	400
2200@500	MTS30D-006A	II	650-2460	580	1150	1600	41	740	250	675	150	300
2200@500	MTS30D-006B	III	650-2460	580	1150	1600	41	740	250	680	150	300
2500@500	MTS30D-007B	III	600-1945	650	1350	1015	41	740	250	720	150	300

## Note:

- ① Obtain the actual capacity of the forklift and attachments from the forklift manufacturer.
- ② Two sets additional oil circuit required on forklift
- ③ Open arm range is the space between two arms tip.
- ④ Arm thickness" C" is the actual requested operation space.
- ⑤ Please contact the sales from HUAMAI.

## Hydraulic Flow & Pressure

Model	Min. Hydraulic Flow(L/min)	Rec. Hydraulic Flow(L/min)	Max. Hydraulic Flow(L/min)	Min. Hydraulic Pressure(Bar)	Max. Hydraulic Pressure(Bar)
MTS15D	15	25	25	35	160
MTS20D	15	25	25	35	160
MTS30D	15	40	40	35	160

## Options

- Heightening and thickening arm
- Left and right clip arm independent movement type
- 180 degree rotation stopping mechanism

# 8 Foam Rubber Clamps



## Application

Foam Clamps can efficiently and safely handle and stack any type of cotton products including rubber ,chemical industry and chemical fiber ,etc.

## Features

- Proven durable T-beam arm aluminium frame construction.
- Superior arm-slide bearing for extended service life.
- Excellent driver visibility.
- Regenerative hydraulic valving for optimal arm speed.
- Thin arm designed, easy to permit close stacking.

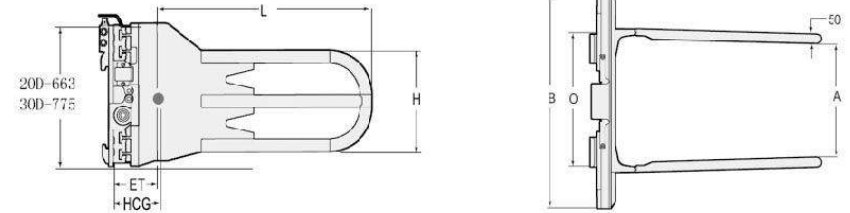

## Specification

Capacity@Load Center	Model	Mounting Class	Opening Range	Arm Height	Arm Length	Frame Width	Arm Thickness	Overall Height	Vertical Center Of Gravity	Weight	Effective Thickness	Horizontal Center Of Gravity
(kg@mm)			A (mm)	H (mm)	L (mm)	B (mm)	C (mm)	(mm)	VCG (mm)	KG	ET (mm)	HCG (mm)
500@500	FMS20D-001A	II	1260-2630	417	1040	47	665	221	465	465	127	310
600@500	FMS20D-002A	II	850-2230	417	1041	47	665	221	430	430	127	280
500@1000	FMS20D-003A	II	900-2300	400	1041	50	665	221	475	475	167	280
200@1000	FMS20D-004A	II	1750-3150	400	1900	50	665	221	650	650	167	280
500@1000	FMS20D-005A	II	1000-2400	400	141	50	665	221	490	490	167	280
1000@500	FMS20D-006A	II	900-2300	600	1041	50	665	221	475	457	167	280
2200@500	FMS30D-007B	III	790-2600	600	1600	60	730	250	800	800	200	280
2200@500	FMS30D-008B	III	790-2600	400	1600	60	730	250	800	785	200	280

### Note:

- ① Obtain the actual capacity of the forklift and attachments from the forklift manufacturer.
- ② Two sets additional oil circuit required on forklift.
- ③ Open arm range is the space between two arms tip.
- ④ Arm thickness " C " is the actual requested operation space.
- ⑤ Please contact the sales from HUAMAI.

## Hydraulic Flow & Pressure

Model	Min. Hydraulic Flow(L/min)	Rec. Hydraulic Flow(L/min)	Max. Hydraulic Flow(L/min)	Min. Hydraulic Pressure(Bar)	Max. Hydraulic Pressure(Bar)
FMS20D	15	25	25	35	160
FMS30D	15	40	40	35	160

## Options

Heightening and thickening arm

Left and right clip arm independent movement type

# 9 Multi Purpose Clamps

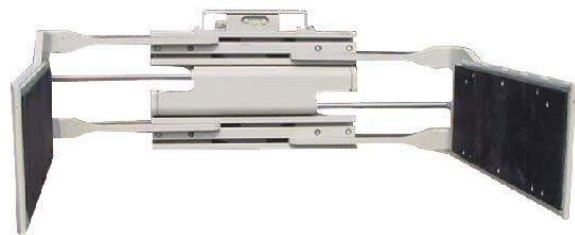

## Application

Efficiently and economically handle nearly any types of paper carton, wooden carton, metal carton and baled products. Including tobacco, newsprint, chemical fiber, workshop and port. High efficiency and economy to handle in without work platform

## Features

- Proven durable T-beam arm aluminium frame construction
- Excellent operation field for vision.
- Regenerative hydraulic valving for optional arm speed
- Superior arm-slide bearing for extended service life
- Vulcanized rubber pads design, economically.

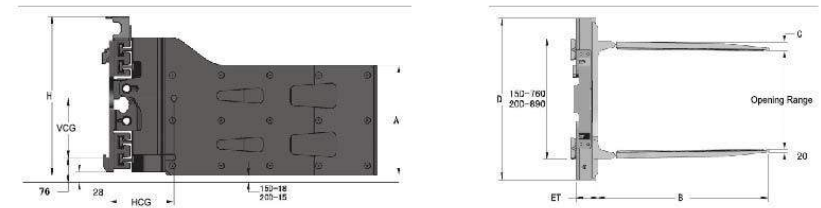

## Specification

Capacity@Load Center	Model	Mounting Class	Opening Range	Arm Height	Arm Length	Frame Width	Arm Thickness	Over all Height	Vertical Center of Gravity	Weight	Effective Thickness	Horizontal Center of Gravity
(kg@mm)			(mm)	A (mm)	B (mm)	D (mm)	C (mm)	H (mm)	VCG (mm)	(kg)	ET (mm)	HCG (mm)
1400@500	MCS15D-001A	II	420-1570	455	955	865	55	665	260	465	175	355
1400@500	MCS15D-002A	II	520-1720	415	1220	865	70	665	220	485	195	415
1900@500	MCS20D-003A	II	520-1750	600	1015	940	75	665	265	475	175	366
1900@500	MCS20D-004A	II	560-1760	455	955	940	55	665	260	475	175	350
1900@500	MCS20D-005A	II	520-1720	415	1220	940	70	665	220	495	195	410
1900@500	MCS20D-006A	II	560-1800	460	750	940	55	665	220	356	180	236
1900@500	MCS20D-007A	II	550-1800	460	905	940	55	665	220	386	180	292
2700@500	MCS30D-008B	III	600-1950	455	750	1015	60	730	255	484	215	215
2700@500	MCS30D-009A	II	600-1950	455	955	1015	60	730	255	542	205	275
2700@500	MCS30D-009B	III	600-1950	455	955	1015	60	730	255	543	215	270
2700@500	MCS30D-010A	II	595-1940	455	1160	1015	65	730	255	603	205	340
2700@500	MCS30D-010B	III	595-1940	455	1160	1015	65	730	255	604	215	330

## Note:

- ① Obtain the actual capacity of the forklift and attachments from the forklift manufacturer.
- ② Two sets additional oil circuit and magnetic valve required on forklift.
- ③ Open arm range is the space between two arms tip.
- ④ Arm thickness "C" is the space size required for practical work, is different from the actual arm plate thickness.
- ⑤ Please contact the sales from HUAMAI.

## Hydraulic Flow & Pressure

Model	Min. Hydraulic Flow(L/min)	Rec. Hydraulic Flow(L/min)	Max. Hydraulic Flow(L/min)	Min. Hydraulic Pressure(Bar)	Max. Hydraulic Pressure(Bar)
MCS20D	15	25	25	35	160
MCS30D	15	40	40	35	160
MCR20D	20	40	60	35	160
MCR30D	20	40	60	35	160

## Options

- Clamp arm height and large extension
- Left and right clip arm independent movement type
- 180 degree rotation stopping mechanism

Multi Purpose Clamps

# 10 Fork Clamps Rotator

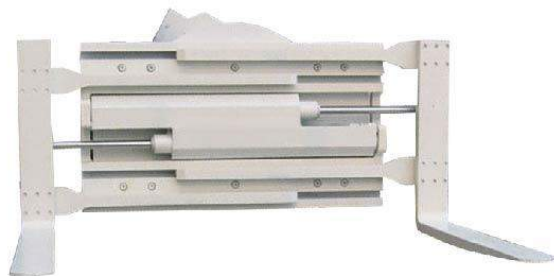

## Application

Revolving Fork clamps not only can be used for holding cargo, but also can be used for forking goods with pallet. Improve transport efficiency , reduce the damage of tray apply to tobacco, paper making, chemical fiber, workshop ,ports and other industries rapid handing and stacking operation.

## Features

- Proven durable T-beam arm aluminum frame construction.
- Superior arm-side bearing for extended service life.
- Regenerative hydraulic valving for optimal arm speed.
- Excellent driver visibility.

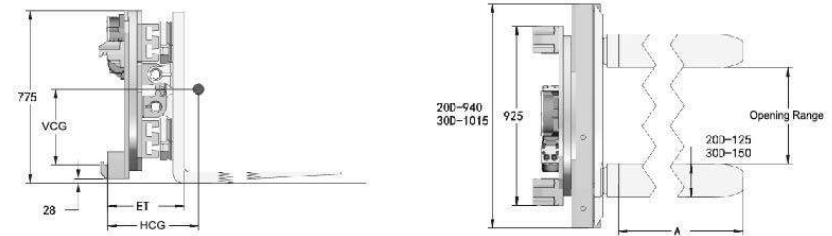

## Specification

Capacity @ Load Center (kg@mm)	Model	Mounting Class	Opening Range (mm)	Fork Length A (mm)	Fork Width D (mm)	Overall Height H (mm)	Vertical Center of Gravity VCG (mm)	Weight (kg)	Effective Thickness ET (mm)	Horizontal Center of Gravity HCG (mm)
1600@600	CFR20D-101A	II	410-1660	915	940	775	280	561	287	188
1600@600	CFR20D-102A	II	410-1660	1065	940	775	275	579	287	213
2300@600	CFR20D-103A	II	410-1660	1220	940	775	265	597	287	230
2300@600	CFR30D-108A	II	440-1785	1065	1015	775	275	685	305	225
2300@600	CFR30D-108B	III	440-1785	1065	1015	775	275	704	345	262
2300@600	CFR30D-109A	II	440-1785	1220	1015	775	270	695	305	249
2300@600	CFR30D-109B	III	440-1785	1220	1015	775	270	712	345	287

### Note:

- ① Obtain the actual capacity of the forklift and attachments from the forklift manufacturer.
- ② Two sets additional oil circuit required on forklift.
- ③ Opening arm can be added on the fork clamps as requires
- ④ Provide the different fork demand as requires
- ⑤ Please contact the sales from HUAMAI.

## Hydraulic Flow & Pressure

Model	Min. Hydraulic Flow(L/min)	Rec. Hydraulic Flow(L/min)	Max. Hydraulic Flow(L/min)	Min. Hydraulic Pressure(Bar)	Max. Hydraulic Pressure(Bar)
CFR20D	15	25	25	35	160
CFR30D	15	40	40	35	160

## Rotator Specification:

Model	Rotator Speed	Rotator Torque
CFR20D	5.2r/min@57L/min	9000N.M@160Bar
CFR30D	5.2r/min@57L/min	9000N.M@160Bar

## Options

Fork Sizes

Various mounting classes available

Custom opening ranges

# 10 Fork Clamps Sideshifter



## Application

Fork clamps not only can be used for holding cargo, but also can be used for forking goods with pallet. Improve transport efficiency, reduce the damage of tray apply to tobacco, paper making, chemical fiber, workshop, ports and other industries rapid handling and stacking operation.

## Features:

- Proven durable T-beam arm aluminum frame construction.
- Superior arm-side bearing for extended service life.
- Regenerative hydraulic valving for optimal arm speed.
- Excellent driver visibility.

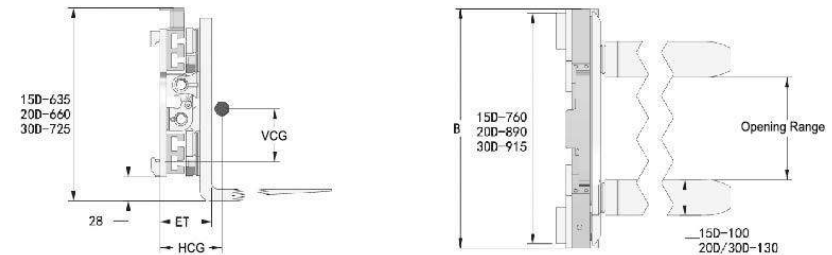

## Specification

Capacity@ Load Center	Model	Mounting Class	Opening Range	Fork Length	Frame Width	Overall Height	Vertical Center of Gravity	Weight	Effective Thickness	Horizontal Center of Gravity
(kg@mm)			(mm)	A (mm)	B (mm)	H (mm)	VCG (mm)	(kg)	ET (mm)	HCG (mm)
1100@600	CFS15D-001A	II	435-1555	915	865	620	175	250	175	163
1100@600	CFS15D-002A	II	435-1555	1065	865	620	165	259	175	191
1100@600	CFS15D-003A	II	435-1555	1220	865	620	150	268	175	226
1600@600	CFS20D-004A	II	410-1660	915	940	620	185	295	180	168
1600@600	CFS20D-005A	II	410-1660	1065	940	620	175	306	180	198
1600@600	CFS20D-006A	II	410-1660	1220	940	620	170	328	180	231
2300@600	CFS30D-001A	II	465-1810	915	1015	915	215	401	208	173
2300@600	CFS30D-001B	III	465-1810	915	1015	915	210	422	216	168
2300@600	CFS30D-002A	II	465-1810	1065	1015	915	195	420	208	203
2300@600	CFS30D-002B	III	465-1810	1065	1015	915	200	438	216	201
2300@600	CFS30D-003A	II	465-1810	1220	1015	915	190	435	208	226
2300@600	CFS30D-003B	III	465-1810	1220	1015	915	190	4	216	201

## Note:

- ① Obtain the actual capacity of the forklift and attachments from the forklift manufacturer.
- ② Two sets additional oil circuit required on forklift.
- ③ Opening arm can be added on the fork clamps as requires
- ④ Provide the different fork demand as requires
- ⑤ Please contact the sales from HUAMAI.

## Hydraulic Flow & Pressure

Model	Min. Hydraulic Flow(L/min)	Rec. Hydraulic Flow(L/min)	Max. Hydraulic Flow(L/min)	Min. Hydraulic Pressure(Bar)	Max. Hydraulic Pressure(Bar)
CFS15D	15	25	25	35	160
CFS20D	15	25	25	35	160
CFS30D	15	40	40	35	160

## Options

- Fork Sizes
- Various mounting classes available
- Custom opening ranges

# 11 Turnloads

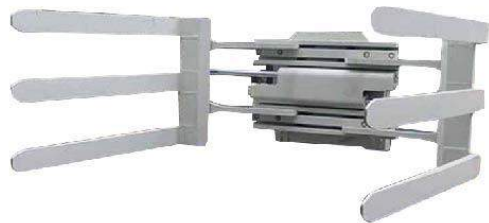

## Application

Turnloads can not only be used for holding cargos, but also be used for forking goods with pallet. Improve transport efficiency, reduce the damage of tray. Turnloads applied to tobacco, papemaking, chemical fiber, waste, ports and other industries. Rapid handing and stacking operation.

## Features

- High-strength all-steel structure design, allows high efficiency under continuous operation.
- E-slot in the overall framework to improve the stability of product, to extend the longevity of product.
- Reasonable design, nice outlook, using the world's most high-quality hydraulic components.
- Fast arm opening speeds with less energy consumption.
- Rugged lightweight construction.
- High net capacity.
- Excellent visibility.

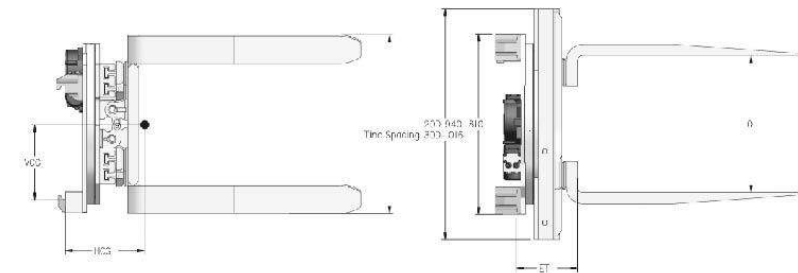

## Specification

Capacity@ Load enter (kg@mm)	Model	Mounting Class	Opening Range (mm)	Fork Size T (mm)	Frame Width D (mm)	Fork Spacing (mm)	Vertical Center of Gravity VCG (mm)	Weight (kg)	Effective Thickness ET (mm)	Horizontal Center of Gravity HCG (mm)
1600@600	TAL20D-001A	II	580-1860	50X125X1000	1040	450	265	720	300	330
1600@600	TAL20D-002A	II	480-1720	45X125X1070	940	700	265	680	295	325
1600@600	TAL20D-003A	II	620-1900	50X125X1200	940	560	265	750	300	330
1600@600	TAL20D-004A	II	715-1960	45X125X1220	940	850	265	662	295	325
1600@600	TAL20D-005A	II	660-1900	45X125X1220	940	450	265	750	295	325
1600@600	TAL20D-006A	II	555-1830	50X125X1200	1040	560	265	750	300	330
1600@600	TAL20D-007A	II	618-1830	40X125X1220	940	635	265	662	290	325
2300@600	TAL30D-001B	III	640-1970	50X125X1220	1015	635(4 FORKS)	270	780	345	300
2300@600	TAL30D-002B	III	710-2060	50X125X1500	1015	890(6 FORKS)	270	980	345	300
2300@600	TAL30D-003B	III	710-2060	50X125X1220	1015	890(4 FORKS)	270	780	345	300
2300@600	TAL30D-004B	III	770-2115	50X125X1220	1015	890(4 FORKS)	270	790	345	300
2300@600	TAL30D-005B	III	710-2060	50X125X1220	1015	635(4 FORKS)	270	780	345	300
2300@600	TAL30D-006B	III	640-1950	50X150X1220	1050	635(4 FORKS)	270	880	345	300
2300@600	TAL30D-007B	III	710-2060	50X150X1220	1015	754(4 FORKS)	270	760	345	300

### Note:

- ① Obtain the actual capacity of the forklift and attachments from the forklift manufacturer.
- ② Two sets additional oil circuit required on forklift
- ③ Opening range is the space between two arms tip.
- ④ Fork size can be customized according to user requirements.
- ⑤ Please contact the sales from HUAMAI.

## Hydraulic Flow & Pressure

Model	Min. Hydraulic Flow(L/min)	Rec. Hydraulic Flow(L/min)	Max. Hydraulic Flow(L/min)	Rec. Hydraulic Pressure(Bar)	Max. Hydraulic Pressure(Bar)
TAL20D	20	40	60	35	160
TAL30D	20	40	60	35	160

## Rotator Specification

Model	Rotator Speed	Rotator Torque
TAL20D	5.2r/min@57L/min	9000N.M@160Bar
TAL30D	5.2r/min@57L/min	9000N.M@160Bar

## Options

- Forks  
180 degree rotation stopping mechanism

# 12 Carton Clamps

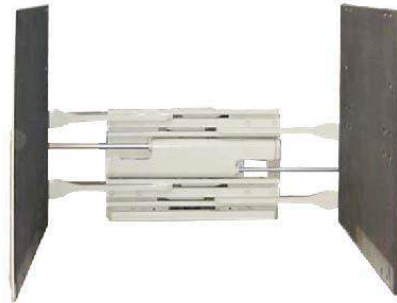

## Application

Carton Clamps are designed for the warehousing ,beverage, home-appliance and electronics industries, carton clamps allow palletless handling, and save money on pallet purchasing, maintenance. Also improve warehouse space utilization.

## Features

- Proven durable T-beam arm aluminum frame construction.
- Regenerative hydraulic valving for optimal arm speed.
- Superior arm-slide bearing for extended service life.
- Vulcanized rubber pads design, economically.
- Excellent driver visibility.

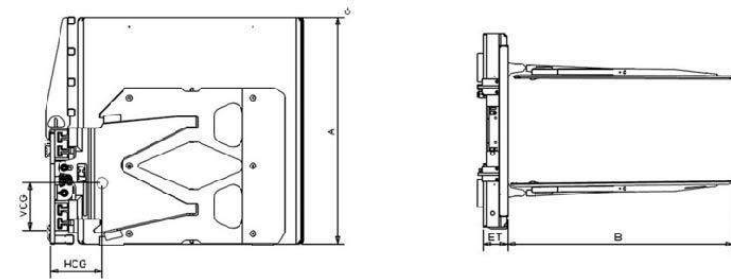

## Specification

Capacity@ Load Center (kg@mm)	Model	Opening Range (mm)	Mounting Class	Arm Height A (mm)	Arm Length B (mm)	Frame Width D (mm)	Vertical Center of Gravity VCG (mm)	Weight (kg)	Effective Thickness ET (mm)	Horizontal Center of Gravity HCG (mm)
1150@600	CCS15D-001A	380-1530	II	1220	1220	940	320	650	127	439
1600@510	CCS20D-002A	560-1930	II	1200	1065	1040	325	644	127	422
1600@535	CCS20D-003A	560-1930	II	1220	1170	1040	325	651	127	427
1600@585	CCS20D-004A	560-1930	II	1220	1220	1040	315	696	127	447
1600@610	CCS20D-005A	560-1930	II	1220	1220	1040	320	705	127	450
1400@710	CCS20D-006A	560-1930	II	1220	1420	1040	315	770	127	483
1450@685	CCS20D-007A	560-1930	II	1525	1370	1040	380	824	127	485
2300@510	CCS30D-008B	535-1850	III	1525	1015	1015	450	899	152	485
2300@535	CCS30D-009B	535-1850	III	1525	1066	1015	450	906	152	485

### Note:

- ① Obtain the actual capacity of the forklift and attachments from the forklift manufacturer.
- ② Two sets additional oil circuit and magnetic valve required on forklift.
- ③ Open arm range is the space between two arms tip.
- ④ All the carton clamps are equipped with four post pressure regulating valves.
- ⑤ Please contact the sales from HUAMAI.

## Hydraulic Flow & Pressure

Model	Min. Hydraulic Flow(L/min)	Rec. Hydraulic Flow(L/min)	Max. Hydraulic Flow(L/min)	Min. Hydraulic Pressure(Bar)	Max. Hydraulic Pressure(Bar)
CCS15D	15	25	25	35	160
CCS20D	15	25	25	35	160
CCS30D	15	40	40	35	160

## Options

- Four-position pressure regulator valve
- Pad height extension
- Heightening load backrest



# 13 Hinged Forks

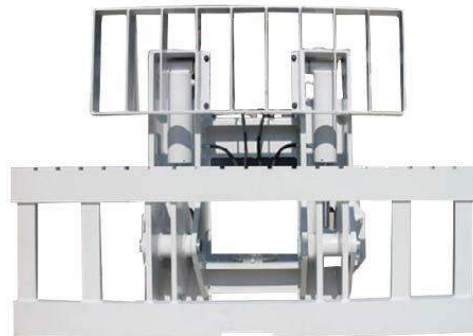

### Application

Hinged forks are safe and efficient to dump bulk cargo container ; Configured with bucket to shovel all loosen goods such as sand, coal, grain, fertilizer, sod and the blocks, ect.

### Features

- Proven durable construction design, overall frame work adopts full steel structure, high strength, can meet the needs of high strength work.
- Body hinger, using polymer composite bushing,hardness is twice as general copper sleeve, fully extended busing life, Because of its self-lubricating fuction without regular filling grease can avoids rapid wear of the lining sleeve for the pin shaft fracture failure.
- Good field of vision, safe and reliable.

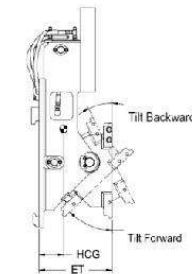
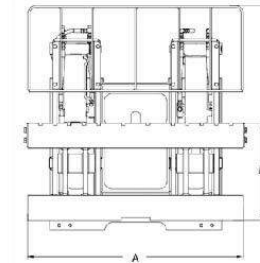

### Specification

Capacity @ Load Center	Model	Carriage Width	Truck Mounting Class	Hinged Forks Mounting Class	Overall Height	Tilt Forward / Tilt Backward	Weight	Effective Thickness	Horizontal Center of Gravity
(kg @ mm)		(mm)			(mm)		(kg)	ET (mm)	HCG (mm)
2000 @ 500	HFB20D-001A	1040	II	II	955	45° / 25°	320	310	132
2500 @ 500	HFB25D-002A	1040	II	II	955	45° / 25°	320	390	132
3000 @ 500	HFB30D-003A	1100	III	III	968	45° / 25°	335	325	132
3500 @ 500	HFB35D-002B	1100	III	III	1175	45° / 25°	400	383	132
4000 @ 500	HFB40D-003B	1100	III	III	1388	45° / 25°	480	395	195
4500 @ 500	HFB45D-004B	1450	III	III	1388	45° / 25°	800	425	195

### Note:

- ① Obtain the actual capacity of the forklift and attachments from the forklift manufacturer.
- ② One/Two sets additional oil circuit required on forklift.
- ③ Can be customized according to customer requirements of various width.
- ④ Please contact the sales from HUAMAI.

### Hydraulic Flow & Pressure

Model	Min.Hydraulic Flow(L/min)	Rec. Hydraulic Flow(L/min)	Max.Hydraulic Flow(L/min)	Rec. Hydraulic Pressure(Bar)	Max. Hydraulic Pressure(Bar)
HFB	19	38	57	35	160

### Options

- Forks
- Bucket
- Heighten load backrest

# 14 Tyre Clamps Single Arm



## Application

Tyre clamps are suitable for all kinds of tyre handling, loading, unloading and stacking operation, widely used in to tyre industry.

## Features

- Proven durable T-beam arm aluminum frame construction.
- Superior arm-side bearing for extended service life.
- Regenerative hydraulic valving for optimal arm speed.
- Durable contact pads, reliable clamping.
- Excellent driver visibility.

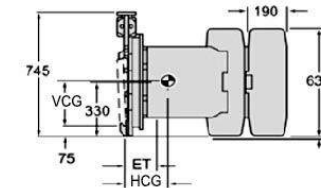
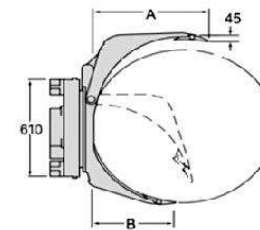

## Specification

Capacity	Model	Mounting Class	Roll Range	Mounting angle	Long Arm Length	Short Arm Length	Long Arm Thickness	Contact Pad size	Weight	Effective Thickness	Horizontal Center of Gravity
(kg)			(mm)		A (mm)	B (mm)	C (mm)	WxH (mm)	(kg)	ET (mm)	HCG (mm)
1200	PTR15F-013A	II	410-1300	0°	790	580	60	230x1500	400	135	216
2000	PTR20F-002A	II	630-1300	0°	825	570	45	300x1500	717	197	282
2000	PTR20F-002B	III	630-1300	0°	825	570	45	300x1500	731	237	320
2000	PTR20F-004A	II	530-1500	0°	955	775	95	300x1500	794	197	280
2000	PTR20F-004B	III	530-1500	0°	955	775	95	300x1500	808	237	304
2000	PTR20F-005A/B	II	630-1600	0°	955	775	95	300x1500	805	183	301
2000	PTR20F-007B	III	680-1830	0°	1130	930	115	300x1500	880	239	445
2000	PTR20F-008B	III	380-1830	0°	1130	930	115	300x1500	886	239	445

### Note:

- ① Obtain the actual capacity of the forklift and attachments from the forklift manufacturer.
- ② Two sets additional oil circuit required on forklift.
- ③ The total height of holding tyre is more than 1/2 clamp pad height, and can't exceed the clamp pad height.
- ④ Please contact the sales from HUAMAI.

## Hydraulic Flow & Pressure

Model	Min. Hydraulic Flow(L/min)	Rec. Hydraulic Flow(L/min)	Max. Hydraulic Flow(L/min)	Min. Hydraulic Pressure(Bar)	Max. Hydraulic Pressure(Bar)
PTR15F	20	40	60	35	160
PTR20F	20	40	60	35	160

## Rotator Specification

Model	Rotator Speed	Rotator Torque
PTR15F	5.2r/min@57L/min	9000N.M@160Bar
PTR20F	5.2r/min@57L/min	9000N.M@160Bar

## Options

Custom opening ranges  
Positioned short arm or fixed short arm

Tyre Clamps

# 14 Tyre Clamps Slip-On Arm



### Application

Slip On Arm Tyre clamps are suitable for all kinds of tyre handling, loading, unloading and stacking operation, widely used in to tyre industry.

### Features

- Easy to use ,Can use as fork clamps, more flexible,also can save money.
- Proven durable T-beam arm aluminum frame construction.
- Superior arm-side bearing for extended service life.
- Regenerative hydraulic valuing for optimal arm speed.
- Durable contact pads, reliable clamping.
- Excellent driver visibility.

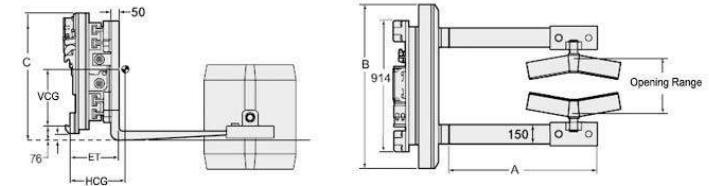

### Specification

Capacity/ Load Center	Model	Mounting Class	Opening Range	Fork Length	Frame Width	Overall Height	Vertical Center of Gravity	Weight	Effective Thickness	Horizontal Center of Gravity
(kg@mm)			(mm)	A (mm)	D (mm)	H (mm)	VCG (mm)	(kg)	ET (mm)	HCG (mm)
2000@500	PTR30D-001B	III	600-2200	1220	1600	775	335	1000	345	400
2000@500	PTR30D-002B	III	600-2200	1220	1600	775	335	990	345	400
2000@500	PTR30D-003B	III	860-2200	1220	1600	775	335	1050	345	400

### Note:

- ① Obtain the actual capacity of the forklift and attachments from the forklift manufacturer.
- ② Two sets additional oil circuit required on forklift.
- ③ The total height of holding tire is more than 1/2 clamp pad height, and can't exceed the clamp pad height.
- ④ Please contact the sales from HUAMAI.

### Hydraulic Flow & Pressure

Model	Min. Hydraulic Flow(L/min)	Rec. Hydraulic Flow(L/min)	Max. Hydraulic Flow(L/min)	Min. Hydraulic Pressure(Bar)	Max. Hydraulic Pressure(Bar)
PTR30D	20	40	60	35	160

### Rotator Specification

Model	Rotator Speed	Rotator Torque
PTR30D	5.2r/min@57L/min	9000N.M@160Bar

### Options

- Custom opening ranges
- Positioned short arm or fixed short arm
- Special pad

Tyre Clamps

# 15 Drum Clamps Sideshifter



## Application

Drum clamps can make the lifting carry two or four oil drums at the same time, to ensure that this is safe and reliable clamping in the process of transportation, significantly improve handling efficiency. Widely used in bulk cargo handling and piling work, such as oil, petrochemical, food and other industries.

## Features

- Proven durable T-beam arm aluminium frame construction
- Superior arm-slide bearing for extended service life
- Regenerative hydraulic valving for optimal arm speed
- Excellent driver visibility
- Rubber pads on clamp arms can be replaced conveniently, it is economic and practical

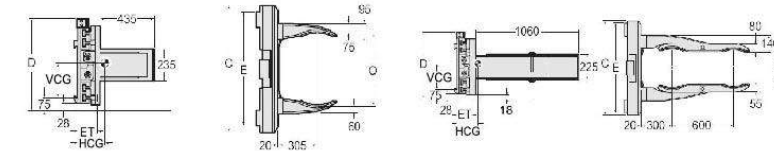

## Specification

Capacity@ Load Center (kg@mm)	Model	Mounting Class	Opening Range (mm)	Arm Height (mm)	Arm Length (mm)	Frame Width C (mm)	Height D (mm)	Weight (kg)	Effective Thickness ET (mm)	Horizontal Center of Gravity HCG (mm)
<b>2 Drums-Sideshifter</b>										
1400@500	DTS15D-001A	II	395-1545	225	435	940	645	285	145	100
1400@500	DTS15D-002A	II	485-1600	225	435	865	620	270	140	107
1400@500	DTS20D-003A	II	520-1750	225	435	940	620	295	145	104
<b>2 Drums-Rotating</b>										
1900@500	DTR20D-004A	II	520-1750	940	755	815	410	522	241	140
<b>4 Drums</b>										
1900@500	DFS15D-005A	III	335-1480	940	645	890	220	385	147	290
1900@500	DFS15D-006A	II	420-1550	865	620	760	210	370	142	312
1900@500	DFS20D-007A	III	460-1690	940	645	890	220	395	147	295
<b>4 Drums-Rotating</b>										
1900@500	DFR20D-008A	III	460-1690	940	775	815	335	613	239	277

### Note:

- ① Obtain the actual capacity of the forklift and attachments from the forklift manufacturer.
- ② Two sets additional oil circuit required on forklift.
- ③ Opening range refers to the radian medial spacing of clamp pad of drum clamp.
- ④ Two drums clamp type can carry one or two drums  
Four drums clamp type can carry one, two or four drums.
- ⑤ Suitable for handling 55 gallon (American:205 liters) of standard oil drum.
- ⑥ Please contact the sales from HUAMAI.

## Hydraulic Flow & Pressure

Model	Min. Hydraulic Flow(L/min)	Rec. Hydraulic Flow(L/min)	Max. Hydraulic Flow(L/min)	Min. Hydraulic Pressure(Bar)	Max. Hydraulic Pressure(Bar)
DTS15D	15	25	25	35	160
DTS20D	15	25	25	35	160
DTR20D	15	25	25	35	160
DFS20D	15	40	40	35	160
DFR20D	15	40	40	35	160

## Rotator Specification

Model	Rotator Speed	Rotator Torque
DTS15D	5.2r/min@57L/min	9000N.M@160Bar
DTS20D	5.2r/min@57L/min	9000N.M@160Bar
DTR20D	5.2r/min@57L/min	9000N.M@160Bar
DFS20D	5.2r/min@57L/min	9000N.M@160Bar
DFR20D	5.2r/min@57L/min	9000N.M@160Bar

## Options

Various mounting classes available  
Custom opening ranges  
Heightening and large clamp arm  
Left and right clip arm independent movement type.

# 16 No-Arm Clamps

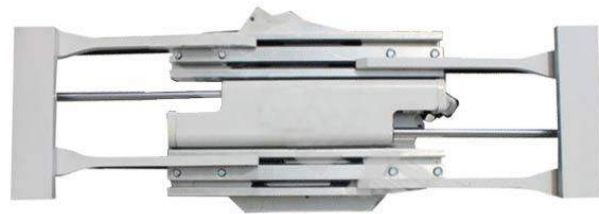

## Application

No arm clamps is a kind of clamping device that isn't equipped with clamp arm, only have the clamp arm base. Users can make special clamp arm according to your special needs, just welding it on no arm clamp then can be used. Suitable for industry with special requirements for handling and stacking operation.

## Features

- Proven durable T-beam arm aluminium frame construction
- Excellent operation field for vision
- Regenerative hydraulic valving for optional arm speed
- Superior arm-slide bearing for extended service life

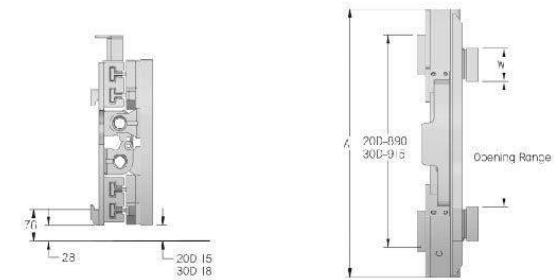

## Specification

Capacity@ Load Center (kg@mm)	Model	Mounting Class	Opening Range O (mm)	Arm Pad Size WxHxT (mm)	Frame Width C (mm)	Vertical Center of Gravity VCG (mm)	Weight (kg)	Effective Thickness ET (mm)	Horizontal Center of Gravity HCG (mm)
1100@600	CNS15D-001A	II	435-1555	100x535x36	865	210	207	122	76
1600@600	CNS20D-002A	II	410-1660	130x565x40	940	220	232	127	76
2300@600	CNS30D-003A	II	465-1810	130x625x45	1015	255	320	142	89
2300@600	CNS30D-003B	III	465-1810	130x625x45	1015	255	338	150	86
1600@600	CNR20D-004A	II	410-1655	127x565x40	940	335	454	226	127
2300@600	CNR30D-005A	II	465-1810	125x625x45	1015	335	536	241	142
2300@600	CNR30D-005B	III	465-1810	125x65x45	1015	335	554	279	188

### Note:

- ① Obtain the actual capacity of the forklift and attachments from the forklift manufacturer.
- ② Two sets additional oil circuit and magnetic valve required on forklift.
- ③ Open range refers to inside spacing of arm base of clamp arm.
- ④ We can design and manufacture various types of special clamp arm according to user's condition requirements.
- ⑤ Please contact the sales from HUAMAI.

## Hydraulic Flow & Pressure

Model	Min. Hydraulic Flow(L/min)	Rec. Hydraulic Flow(L/min)	Max. Hydraulic Flow(L/min)	Min. Hydraulic Pressure(Bar)	Max. Hydraulic Pressure(Bar)
Sideshifting					
CNS20D	15	25	25	35	160
CNS30D	15	40	40	35	160
Rotating					
CNR20D	15	25	25	35	160
CNR30D	15	40	40	35	160

## Rotator Specification

Model	Rotator Speed	Rotator Torque
CNR20D	5.2r/min@57L/min	9000N.M@160Bar
CNR30D	5.2r/min@57L/min	9000N.M@160Bar

## Options

Various mounting classes available  
Custom opening ranges

# 17 Bag Load Pushes



### Application

Bag Load Push is designed for heavy use under harsh conditions. Non-slip-sheeted goods can be pushed into position with brute force against other loads in order to create straight positioning and to optimize space inside sea containers.

### Features

- High strength steel structure design, meet user efficient continuous operation.
- Meet the job in different working conditions.
- Reasonable design, good field of vision

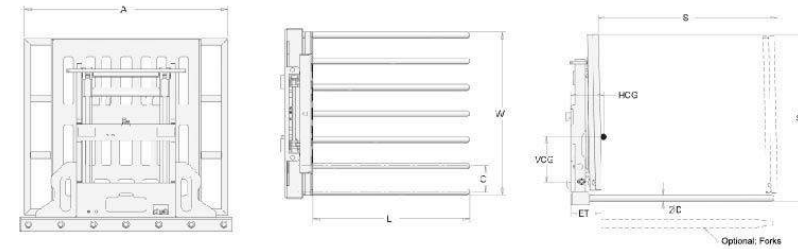

### Specification

Capacity@ Load Center (kg@mm)	Model	Mounting Class	Width of Faceplate (mm)	Height of Faceplate (mm)	Sideshit (mm)	Stroke (mm)	Round Diamensions (mm)	Number of Round Bars	Weight (kg)	Effective Thickness ET (mm)	Horizontal Center Of Gravity HCG (mm)
1600@600	PLB20D-001A	II	1000	1000	null	1180	Φ55x1200	6	550	241	329
2500@600	PLB30D-002B	III	1000	1000	null	1180	Φ55x1200	6	590	241	329
2500@600	PLS30D-003B	III	1000	1000	+/-100	1280	Φ55x1300	6	650	241	329
2500@600	PLS30D-004B	III	1000	1000	null	1180	Φ55x1200	6	620	241	329
2500@600	PLS30D-005B	III	1200	1200	+/-100	1280	Φ55x1300	6	680	241	329
2500@600	PLS30D-006B	III	1200	1200	null	1180	Φ55x1200	6	650	241	329
2500@600	PLS30D-007B	III	1200	1200	+/-100	1380	Φ55x1400	6	710	241	329

### Note:

- ① Obtain the actual capacity of the forklift and attachments from the forklift manufacturer.
- ② One/Two sets additional oil circuit required on forklift.
- ③ Please contact the sales from HUAMAI.

### Hydraulic Flow & Pressure

Model	Min. Hydraulic Flow(L/min)	Rec. Hydraulic Flow(L/min)	Max. Hydraulic Flow(L/min)	Min. Hydraulic Pressure(Bar)	Max. Hydraulic Pressure(Bar)
PLB20D	20	40	60	35	160
PLB30D	20	40	60	35	160

### Options

- Fork/Round Bar
- Extended and lengthen push board

Bag Load Pushes

# 18 Steel Pipe Clamps



## Application

Steel pipe clamp can efficiently handle and stack hard, cylindrical objects under normal temperature without pallet. Widely used in construction, logistics industries for handling the steel pipe etc, the functions of tipping and withhold can greatly improve the flexibility of the forklift and handling efficiency.

## Features

- Hydraulic system: imported original fuel tank check valve; seal products are imported, high-pressure hose with cone seal imports of high-performance hose.
- Mechanical properties: the external lateral features, plug-fork be used in conjunction to achieve the forward hold folders, adding in each tank check valve, can achieve long packing, ensure that the work or the plastic Pipe burst of safety.
- An important component of a product application and configuration, Competitive Quality
- Lubrication system at active joints can ensure durable usage life.
- Excellent driver visibility.

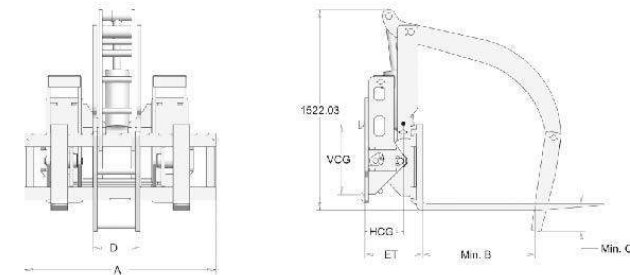

## Specification

Model	Capacity (kg)	Mounting Class	Rotator/ Fork Mounting	Height of Faceplate	Tilt Forward /Tilt Backward	Raker Opening	Raker Width	Weight (kg)	Effective Thickness	Horizontal Center of Gravity
				A (mm)	(mm)	C (mm)	D (mm)		ET (mm)	HCG (mm)
HKB30D-011B	3000@600	III	III	1300	45° /12°	-180/1600	355	880	385	292
HKB 45D-002B	4500@600	III	III	1650	45° /12°	-180/1600	355	1020	401	305
HKB 45D-002C	4500@600	IV	III	1650	45° /12°	-180/1600	355	1060	401	315

### Note:

- ① Obtain the actual capacity of the forklift and attachments from the forklift manufacturer.
- ② Two sets additional oil circuit required on forklift.
- ③ Please contact the sales from HUAMAI.

## Hydraulic Flow & Pressure

Model	Min. Hydraulic Flow(L/min)	Rec. Hydraulic Flow(L/min)	Max. Hydraulic Flow(L/min)	Min. Hydraulic Pressure(Bar)	Max. Hydraulic Pressure(Bar)
HKB30D	20	40	60	35	160
HKB40D	38	57	91	35	160

## Options

Lengthen Bar Carriage

# 19 Hinged Broke Handlers



### Application

Used for clamping handling all kinds of standard packaging of goods. Such as waste paper, straw, chemical fiber, etc. Widely used in farming and animal husbandry, recycling industry, textile and other industries.

### Features

- High strength steel structure design, meet user efficient continuous operation.
- The one-way valve clamp of arm oil cylinder has the function to guarantee the pressure, to ensure the safe and reliable in the process of use.

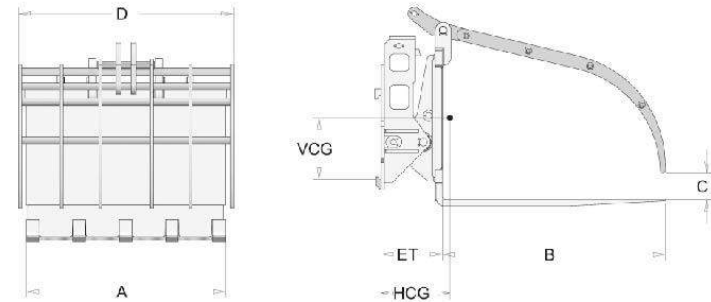

### Specification

Capacity@ Load Center (kg@mm)	Model	Mounting Class	Fork Length A (mm)	Fork Width B (mm)	Tilt Forward/Tilt Backward (mm)	Raker Opening C (mm)	Raker Width D (mm)	Stroke (mm)	Fork Size (mm)	No. of Forks	Weight (kg)	Effective Thickness ET (mm)	Horizontal Center Of Gravity HCG (mm)
2500@600	HKB30D-007B	III	1250	1200	45° /12°	-180/1800	1265	1180	40x80x1220	5	940	390	460
2500@600	HKB30D-008B	III	1250	1400	45° /12°	-180/1800	1265	1180	40X80X1400	5	990	390	468

### Note:

- ① Obtain the actual capacity of the forklift and attachments from the forklift manufacturer.
- ② Two sets additional oil circuit required on forklift.
- ③ Please contact the sales from HUAMAI.

### Hydraulic Flow & Pressure

Model	Min. Hydraulic Flow(L/min)	Rec. Hydraulic Flow(L/min)	Max. Hydraulic Flow(L/min)	Min. Hydraulic Pressure(Bar)	Max. Hydraulic Pressure(Bar)
HKB30D	20	40	60	35	160

### Options

Different fork width and length  
Different mounting class

Hinged Broke Handlers



# 20 PUSH/PULLS

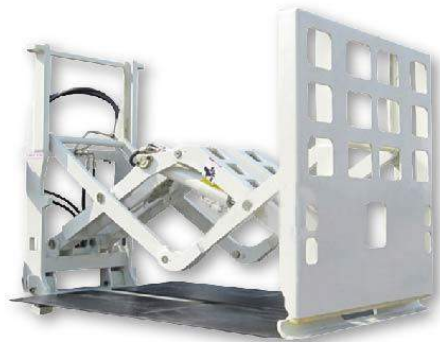

## Application

Push pull used for handing the skateboard bag, carton or bottled goods, realize the high efficiency, low maintenance costs without pallet handling and stacking.

## Features

- High strength steel structure design, meet user efficient continuous operation.
- Meet the job in different working conditions.
- Reasonable design, good field of vision

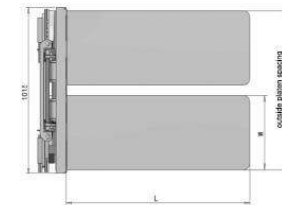
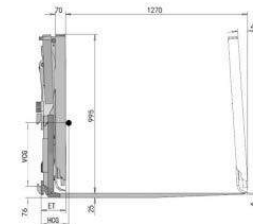

## Specification

Capacity@Load Center	Model	Sheet Saved Type	Mounting Class	Platen Size	Outside Platen Spacing	Minimum Truck Carriage Width	Vertical Center of Gravity	Weight	Effective Thickness	Horizontal Center Of Gravity
(kg@mm)				(mm)	(mm)	(mm)	VCG (mm)	(kg)	ET (mm)	HCG (mm)
<b>Quick Mounted</b>										
<b>Sideshifting</b>										
1600@600	QPB35E-001A	Sheet Not Saved	II	455*1220	1015-1170	790	307	347	165	246
1600@600	QPB35E-003A	Sheet Not Saved	II	380*1220	865-1015	790	320	336	165	226
<b>Non- Sideshifting</b>										
2000@600	QPA45E-001A	Sheet Saved	II	455*1220	1015-1170	790	295	361	165	264
2000@600	QPA45E-003A	Sheet Saved	II	380*1220	865-1015	790	307	347	165	246
<b>Standard</b>										
<b>Non- Sideshifting</b>										
1600@600	PPS35E-001A	Sheet Not Saved	II	455*1220	1015-1220	915	223	502	165	221
1600@600	PPS35E-003A	Sheet Not Saved	II	380*1220	865-1065	915	236	480	165	203
2000@600	PPS45E-001A	Sheet Not Saved	II	455*1220	865-965	915	216	516	165	231
2000@600	PPS45E-003A	Sheet Not Saved	II	380*1220	865-1065	915	229	491	165	211
<b>Sideshifting</b>										
1600@600	PPB35E-001A	Sheet Not Saved	II	455*1220	1015-1220	710	223	495	165	223
1600@600	PPB35E-003A	Sheet Not Saved	II	380*1220	865-1065	710	239	473	165	206
2000@600	PPB45E-001A	Sheet Not Saved	II	455*1220	1015-1220	710	218	509	165	234
2000@600	PPB45E-003A	Sheet Not Saved	II	380*1220	865-1065	710	231	484	165	213
<b>Non- Sideshifting</b>										
1600@600	PAS35E-001A	Sheet Saved	II	455*1220	1015-1220	915	208	634		229
1600@600	PAS35E-003A	Sheet Saved	II	380*1220	1015-1115	915	223	604		229
2000@600	PAS45E-001A	Sheet Saved	II	455*1220	1015-1115	915	208	634		229
2000@600	PAS45E-003A	Sheet Saved	II	380*1220	865-965	915	223	604		229

### Note:

- ① Obtain the actual capacity of the forklift and attachments from the forklift manufacturer.
- ② One/Two sets additional oil circuit required on forklift.
- ③ Please contact the sales from HUAMAI.

### Options

Fork/Round Bar  
Extended and lengthen push board

## Hydraulic Flow & Pressure

Model	Min. Hydraulic Flow(L/min)	Rec. Hydraulic Flow(L/min)	Max. Hydraulic Flow(L/min)	Min. Hydraulic Pressure(Bar)	Max. Hydraulic Pressure(Bar)
PPB35E	20	40	60	35	160
PPB45E	20	40	60	35	160
PAS35E	20	40	60	35	160
PAS45E	20	40	60	35	160
QPB35E	20	40	60	35	160
QPB45E	20	40	60	35	160

# 21 Inverta Pushes



## Application

Applied to the carrying, loading, unloading and stacking with pallets of bagged goods (especially for soft bagged goods) such as plastic particles, cement, chemical fertilizer, fodder, rice, etc. Without manual work, the goods can be revolved 180 degree, pushed off and pallets can be taken out, being safe, efficient and labor saving.

## Features

- High safety performance is ensured for its two-way hydraulic rotation within 360° and self locking at any angle.
- A safety valve is equipped to avoid damage to the goods once the oil pipe is cracked abruptly.
- Reasonable design, compact structure, broad view and easy for maintenance.
- Hydraulic elements are reasonable in design, durable and with fine visibility,
- The oil-free lubrication system applied to each joint ensures better protection of the pins and axles, free of maintenance.
- The casting alloy steel of the folding part reduces the dead weight of no-load distance of a product and prolongs the forklift's service life.

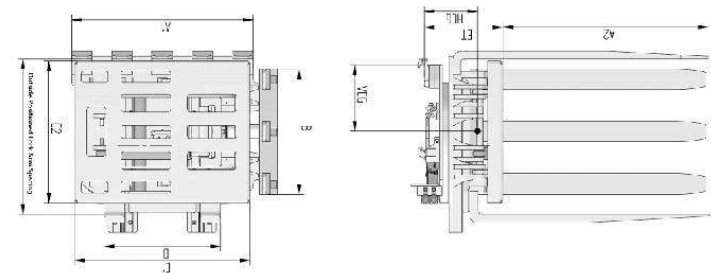

## Specification

Capacity@Load Center	Model	Mounting Class	Opening Range	Platen	Fork Length	Overall Height	Width Of Platen	Height Of Platen	Weight	Effective Thickness	Horizontal Center Of Gravity
(kg@mm)			(mm)	A1	A2	B	C1	C2	(kg)	ET (mm)	HCG (mm)
Sideshifting											
1500	IVS15D-001B	III	600-750	1100	1270	760	1060	860	1380	480	475
2000	IVS20D-001B	III	600-750	1100	1270	760	1060	860	1480	480	475
Non-Sideshifting											
1500	IVP15D-001B	III	600-750	1100	1270	760	1060	860	1320	460	475
2000	IVP20D-001B	III	600-750	1100	1270	760	1060	860	1420	460	475

### Note:

- ① Obtain the actual capacity of the forklift and attachments from the forklift manufacturer.
- ② One/Two sets additional oil circuit required on forklift.
- ③ Please contact the sales from HUAMAI.

## Hydraulic Flow & Pressure

Model	Min. Hydraulic Flow(L/min)	Rec. Hydraulic Flow(L/min)	Max. Hydraulic Flow(L/min)	Min. Hydraulic Pressure(Bar)	Max. Hydraulic Pressure(Bar)
IVS15D	20	40	60	35	160
IVS20D	20	40	60	35	160
IVP15D	20	40	60	35	160
IVP20D	20	40	60	35	160

# 22 Single Double Pallet Handlers



## Application

Enables operator to move forks to handle 1 or 2 loads at one time to improve productivity. Be able to move loads apart or closer together hydraulically when handling 2 loads at a time. When equipped with sideshifting function, it enables the forklift to move its load from side to side to ease stacking, loading and unloading of goods. Used in most industries which has high volume of unitized loads, like beverages, petrochemical, food and logistics.

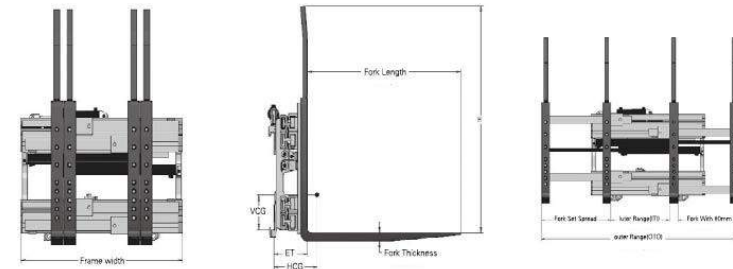

## Specification

Capacity @Load Center	Model	Mounting Class	Minimum Truck Carriage Width	Frame Width	Inner Fork Range	Opening Range	Ave. Pallet Spread	Fork Set Spread	Fork Size	Backrest Height	Vertical Center of Gravity	Weight	Effective Thickness	Horizontal Center of Gravity
(kg@mm)			(mm)	(mm)	ITI (mm)	OTO (mm)			(mm)	(H)	VCG (mm)	(kg)	ET (mm)	HCG (mm)
<b>Beverage Pallets (36"x36", 914mm*914mm)</b>														
2500@600	FDS25G-A005	II	914	1100	330-815	660-2035	508	610	915 x 80 x 45	1220	277	490	226	196
2500@600	FDS25G-B005	III	914	1100	330-815	660-2035	508	610	915 x 80 x 45	1220	277	498	221	191
<b>Block and GMA Pallets(48"x40", 1219mmx1016mm)</b>														
2500@600	FDS25G-A221	II	914	1100	370-730	700-2100	381	685	1065 x 80 x 40	1220	274	531	226	213
2500@600	FDS25G-B221	III	914	1100	370-730	700-2100	381	685	1065 x 80 x 40	1220	282	526	221	208
<b>GMA Pallets (48"x40", 1219mmx1016mm)</b>														
2500@600	FDS25G-A009	II	914	1100	480-790	810-2210	483	710	1065 x 80 x 40	1220	267	514	226	221
2500@600	FDS25G-B009	III	914	1100	480-790	810-2210	483	710	1065 x 80 x 40	1220	272	510	221	216
<b>Container Pallets(44"x59", 1118mmx1422mm)</b>														
2500@600	FDS25G-A013	II	914	1100	330-715	660-2035	279	660	1370 x 80 x 45	1220	246	542	226	287
2500@600	FDS25G-B013	III	914	1100	330-715	660-2035	279	660	1370 x 80 x 45	1220	254	538	221	284
<b>ISO Pallets(1200mmx1000mm)</b>														
2500@600	FDS25G-B500	III	980	1200	330-760	660-2040		640	1150 x 80 x 45	1355	278	517	221	238

## Note:

1. Obtain the actual capacity of the forklift and attachments from the forklift manufacturer.
2. Two sets additional oil circuit required on forklift.
3. Sideshifting left 100mm, right 100mm.

## Hydraulic Flow & Pressure

Model	Min. Hydraulic Flow(L/min)	Rec. Hydraulic Flow(L/min)	Max. Hydraulic Flow(L/min)	Min. Hydraulic Pressure(Bar)	Max. Hydraulic Pressure(Bar)
FDS25G	20	40	60	35	160

## Options

- Heighten load backrest
- Different mounting class

Single Double Pallet Handlers

### Non-standard customization

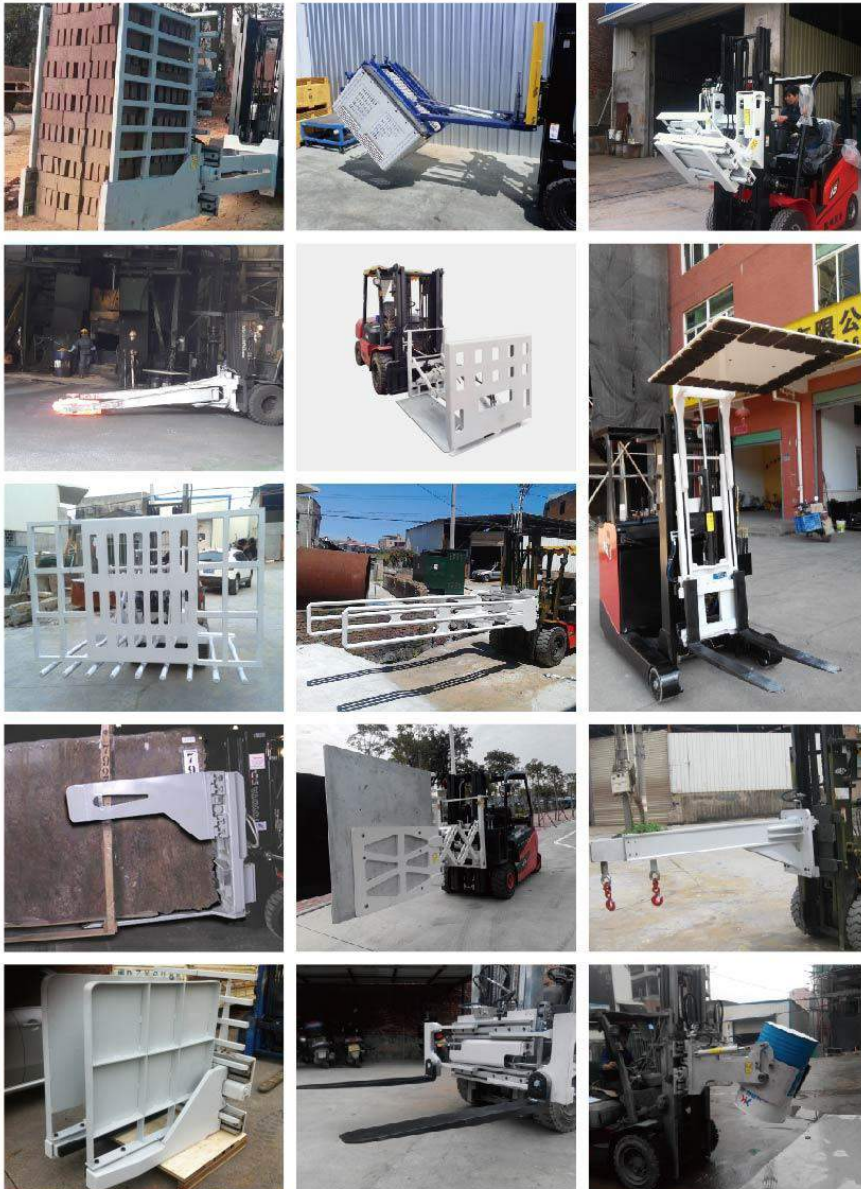

We are looking forward with great expectation to your kindly visiting.